

*UNNO*

*M I T H*

TECHNICAL USER MANUAL

# INTRODUCTION

Welcome to UNNO. You're now part of something special.

The trails are waiting, but first, get to know your new MITH by reading this document carefully. Regardless of how experienced you are as a mountain biker, it'll help you understand the bike better.

Some of the language and terminology might be a bit technical, so if you have any questions, please reach out to us or consult your trusted mechanic at your local bike shop.

Thank you for supporting us.

UNNO MOUNTAIN CYCLES SL  
C. Bolivia 340, Local 27  
08019 Barcelona, Spain  
tel. + 34 933 078 920  
E-mail: [info@unno.com](mailto:info@unno.com)  
[www.unno.com](http://www.unno.com)



# TABLE OF CONTENTS

<b>01 KEY TO SYMBOLS</b>	<b>5</b>	<b>08 GEOMETRY AND SIZING</b>	<b>17</b>
<b>02 BIKE TERMINOLOGY</b>	<b>6</b>	Sizing table	17
<b>03 FIRST ASSEMBLY</b>	<b>7</b>	Maximum and minimum seat heights with dropper seatpost	18
<b>04 MAINTENANCE</b>	<b>9</b>	<b>09 TECHNICAL SPECS</b>	<b>19</b>
Keep your bike clean	9	Technical specifications. Mith 2025	19
Keep your drivetrain lubricated	9	Technical specifications DJI Avinox Drive System	20
Inspect your bicycle before each ride	9	<b>COMPONENTS. EXPLODED VIEWS, ASSEMBLY, USE AND SPARE PARTS</b>	<b>22</b>
Maintenance periods of components	10	<b>10 HEADSET</b>	<b>22</b>
Spare parts	12	Headtube dimensions	22
After an impact or a crash	12	Headset specifications	22
<b>05 USE WARNINGS</b>	<b>13</b>	Headset exploded view and assembly	23
Maximum tire width	13	Headset components	23
Minimum seatpost insertion length	13	<b>11 TOP LINK</b>	<b>24</b>
Maximum fork length (axle to crown)	13	<b>12 LOWER LINK</b>	<b>24</b>
Intended use	13	<b>13 PIVOT POINTS</b>	<b>25</b>
Serial number of your bike	13	<b>14 SHOCK – FRAME AXLE</b>	<b>25</b>
<b>06 WARNINGS REGARDING THE USE OF ELECTRIC SYSTEM</b>	<b>14</b>	<b>15 CHARGING PORT</b>	<b>26</b>
Cleaning drive system	14	<b>16 BATTERY</b>	<b>26</b>
Battery maintenance	14	<b>17 DRIVE UNIT</b>	<b>27</b>
Range	14	<b>18 DISPLAY</b>	<b>27</b>
Transport of electric batteries	14		
Transport of e-bikes	14		
<b>07 USE OF THE DJI AVINOX DRIVE SYSTEM</b>	<b>15</b>		
Control display and wireless controllers	15		
Pair and activate	16		
Device updates	16		
Charging the battery	16		
Identify the charge level of the battery	16		
Avinox App	16		

# TABLE OF CONTENTS

<b>19 REAR TRIANGLE</b>	<b>28</b>
Rear axle	28
Speedsensor	28
Assembly	28
<b>20 SEATCLAMP</b>	<b>29</b>
<b>21 PROTECTORS</b>	<b>29</b>
Drive unit cover	29
Rubber protectors	30
Chainguide	30
<b>22 CABLE ROUTING</b>	<b>34</b>
<b>23 DJI AVINOX ELECTRICAL SYSTEM</b>	<b>36</b>
Components connection diagram	36
Components references	36
Advanced functions	37
Bike protection	37
Troubleshooting and upload logs	39
<b>24 SUSPENSIONS</b>	<b>40</b>
Adjusting the forks	40
Adjusting shocks	40
Shocks compatibility	41
<b>25 WARRANTY</b>	<b>42</b>
Warranty conditions	42
<b>26 DECLARATION OF CONFORMITY</b>	<b>43</b>
<b>27 ADDITIONAL INFORMATION</b>	<b>43</b>



# 01 KEY TO SYMBOLS

This manual includes various symbols to highlight instructions and warnings related to use, maintenance, and assembly.

Understanding these symbols is essential to prevent hazards and ensure the proper assembly and operation of all components.

The symbols are explained below and may be accompanied by instructions relevant to the specific component they refer to. Carefully review the following information to fully understand their significance.

## SAFETY INSTRUCTIONS

 **DANGER:** A dangerous situation that, if not prevented, will result in severe injury or fatality.

 **WARNING:** A dangerous situation that, if not prevented, could result in severe injury or fatality.

 **CAUTION:** A dangerous situation that, if not prevented, could result in minor or moderate injury.

 **NOTICE:** Relevant information, no physical risk involved.

 **RISK OF ELECTRIC SHOCK:** A critical situation that, if not prevented, could result in death or serious injury due to electric shock.

 **SHORT CIRCUIT RISK:** Failure to follow the instructions may result in short circuits in the electrical components, potentially causing damage to the components and a fire.

The symbols **DANGER** and **WARNING** always indicate a risk of accident if preventive measures are not taken. A bicycle accident can result in serious injury or even death. This manual does not repeatedly mention the risk of death each time these symbols appear, as it is already stated here.

## SPECIFIC TOOLS

 SPANNER



 5

12 Nm

The tool size to use appears inside the symbol

The required tightening torque (in Newton meters) is indicated below the symbol of the tool needed for the specified item

 PHILLIPS SCREWDRIVER

## COMPOUND TYPES

 **OIL:** Apply a light layer of lubrication to components such as chains or cables.

 **GREASE:** Apply assembly grease to prevent creaking and seizing

 **CARBON PASTE:** Apply assembly compound to enhance friction between carbon fiber components.

 **LOCTITE 600 SERIES:** Securing cylindrical surfaces

 **LOCTITE 400 SERIES:** Instant adhesive

 **LOCTITE 200 SERIES:** Securing or threadlocks. Medium resistance

# O2 BIKE TERMINOLOGY

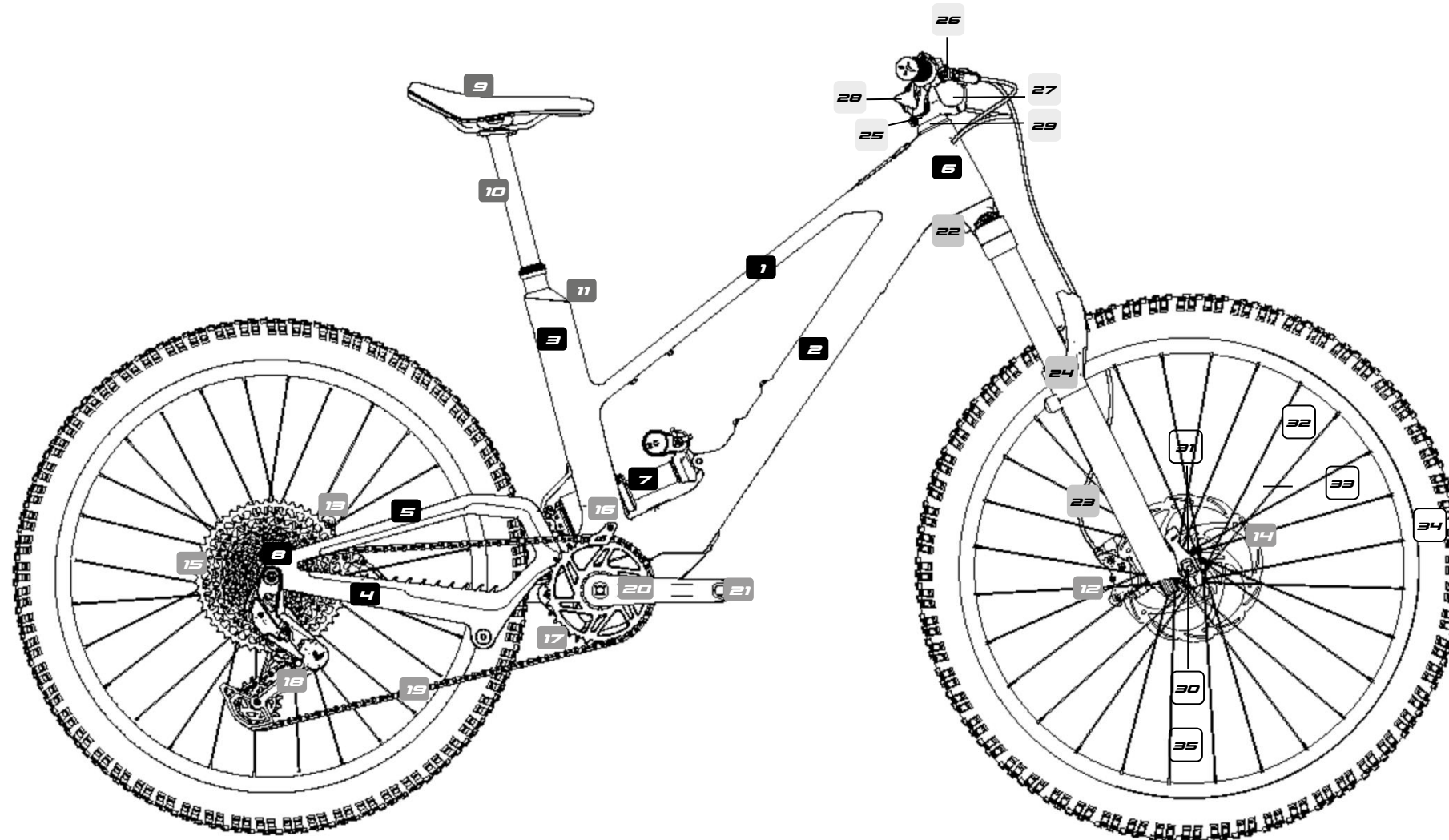

- FRAME**
- 1** Top tube
  - 2** Down tube
  - 3** Seat tube
  - 4** Chainstay
  - 5** Seatstay
  - 6** Headtube
  - 7** Rear shock
  - 8** Dropout
- OTHER COMPONENTS**
- 9** Saddle
  - 10** Seatpost
  - 11** Seatpost clamp
  - 12** Front brake
  - 13** Rear brake
  - 14** Disc
  - 15** Cassette
  - 16** Chainguide
  - 17** Chainring
  - 18** Derailleur
  - 19** Chain
  - 20** Crankset
  - 21** Pedal
  - 22** Crown
  - 23** Stanchions
  - 24** Fork
  - 25** Stem
  - 26** Brake Lever
  - 27** Handlebar
  - 28** Shifter
  - 29** Headset
  - 30** E-ThruAxle
  - 31** Hub
  - 32** Spoke
  - 33** Rim
  - 34** Tire
  - 35** Valve

## 03 FIRST ASSEMBLY

When unboxing the bicycle, it is essential to follow a series of steps to ensure its proper functioning. This not only enhances the user experience but also guarantees comfort and safety during use.

### ASSEMBLING THE REAR BRAKE LEVER

After carefully removing the bicycle from its packaging and discarding all protective cardboard, the next step is to install the rear brake lever onto the handlebar. This process is essential to ensure proper functionality and rider safety. In the following steps, detailed adjustments will be made to position the lever correctly, optimizing comfort and control during use.

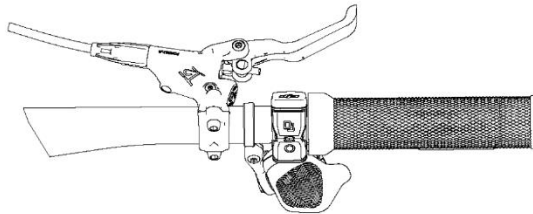

### ASSEMBLING THE HANDLEBAR

Once the handlebar components have been assembled, the handlebar is then installed onto the stem. It is important to take the material of the handlebar into account during this process. If the handlebar is made of carbon, carbon paste should be applied to the area where it connects to the stem. On the other hand, if the handlebar is made of aluminum, no lubricant should be applied.

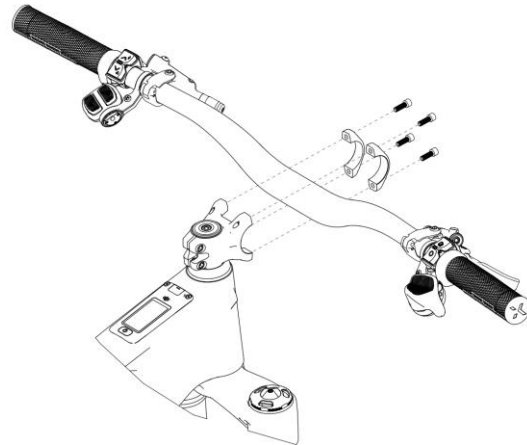

Next, we will proceed to assemble the stem bolts. The tightening sequence should be done in a crisscross pattern to ensure proper contact between the handlebar and the stem. Subsequently, it is important to apply the specified torque to each of these bolts, as defined by the component manufacturer.

### TUBELESS WHEEL SETUP

Next, the rear wheel will be removed to facilitate the introduction of the tubeless sealant in a more efficient and user-friendly manner.

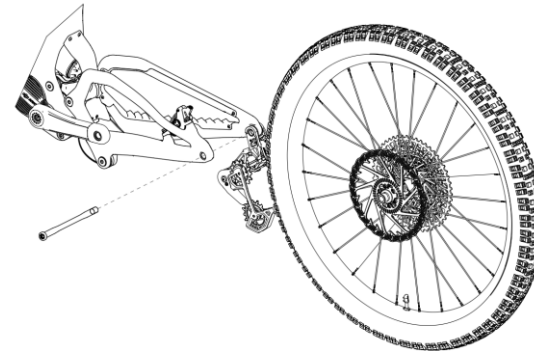

The front wheel is not assembled, so it comes loose and will be easier to handle when introducing the tubeless sealant. Once both wheels are tubeless-ready, the user should ensure the proper application of the tubeless sealant. If unfamiliar with the process, it is recommended to follow the manufacturer's instructions.

If you are unsure about how to carry out this process, we advise taking the bicycle to a specialized workshop or an Unno dealer.

### ASSEMBLING THE WHEELS

Once the wheels are tubeless, the next step is to assemble them. The rear axle will be reinserted into its correct position, and a tightening torque of **12 Nm** will be applied.

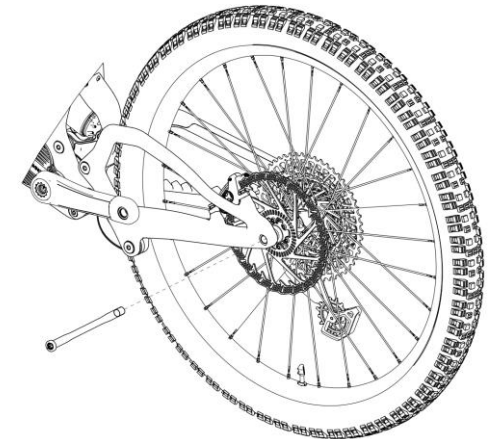

Regarding the front wheel, the front axle will be removed, and the wheel will be placed in its correct position. Once the wheel is properly centered, the front axle, as specified by the fork manufacturer, will be inserted, and the torque should be applied according to the manufacturer's recommended specification.

## 03 FIRST ASSEMBLY

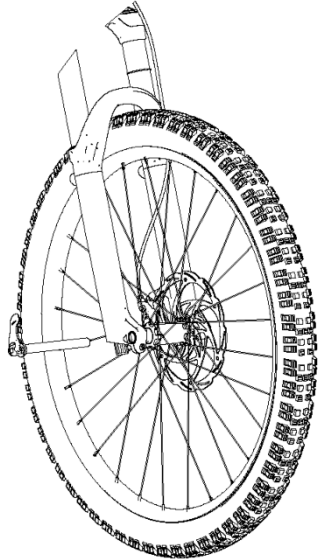

Once this step is completed, make sure to rotate the wheel to verify that it is in the correct position and does not make contact with the brake pads. If there is any rubbing, the position of the front caliper should be adjusted accordingly. After making the necessary adjustments, rotate the wheel again to ensure that it is functioning correctly and that there is no further interference with the brake pads. Proper alignment is crucial for optimal braking performance and to avoid unnecessary wear on the components.

### ASSEMBLING THE SADDLE

Once the previous steps have been completed, we will proceed to mount the saddle. To do this, the upper piece of the dropper seatpost will be removed, and the saddle will be positioned on the corresponding rails.

After positioning the saddle, the upper part of the seatpost will be reattached, and the dropper seatpost bolts will be tightened, but not fully fixed at this stage. Depending on the model of the dropper seatpost, either an Allen wrench or a Torx tool will be used for tightening. It's important to avoid fully tightening the bolts until the saddle is properly aligned and positioned to the user's preference.

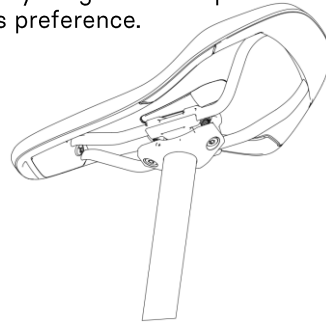

Once the saddle is positioned, its alignment should be adjusted to ensure the rider's comfort during use. Proper saddle positioning is crucial for an optimal riding experience, so make sure to adjust it for the correct angle and height based on the rider's preferences.

After adjusting the saddle to the desired position, proceed to tighten the bolts of the dropper seatpost until they are fully secure. It is essential to use the correct torque value as specified by the dropper seatpost manufacturer to ensure proper fixation and avoid any issues during riding.

### ADJUSTING BRAKE LEVERS AND POD'S

Finally, the last step involves adjusting the brake levers and pods to match the rider's ergonomics, ensuring optimal performance and comfort during bike use.

To adjust the brake levers, the user should first loosen the screws securing the levers to the handlebar. The rider should then mount the bike in their riding position and operate the brake levers. It is important to note that this step should not be performed while seated, as the wrist position while riding differs from that of a seated position. Therefore, the rider must simulate their riding posture, aligning the levers with their wrists and fully extended fingers. This ensures proper alignment, reducing the risk of discomfort or strain in the wrists during use.

Once the ideal lever position is determined, the corresponding screws should be tightened until the levers are securely fixed to the handlebar.

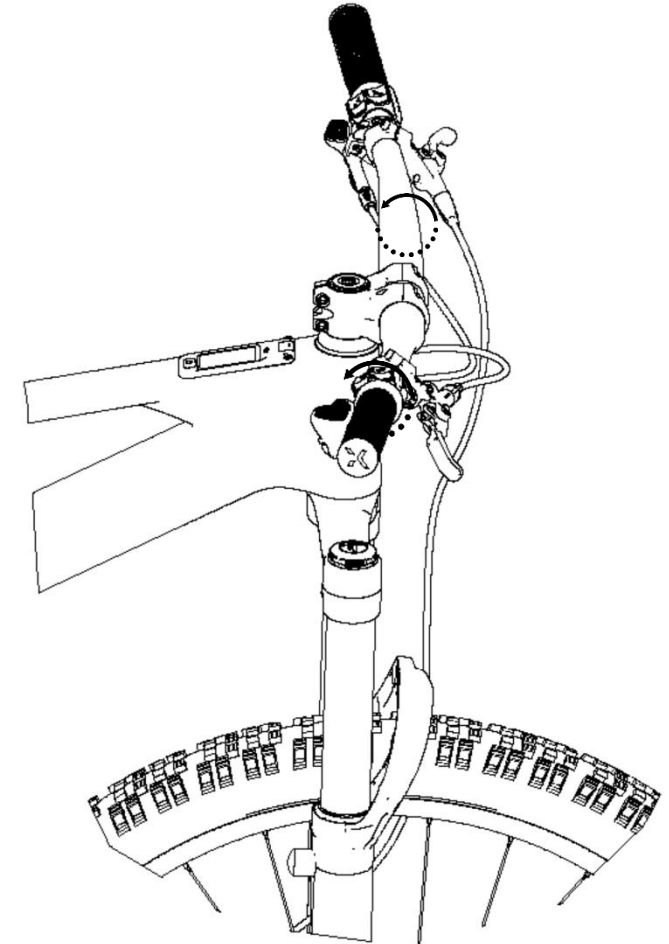

## 04 MAINTENANCE

Unno designs its products with durability, efficiency, and easy upkeep in mind. The aluminum and carbon frames, along with the forks, offer exceptional resistance to corrosion. However, to maintain optimal performance, safety, and longevity, routine servicing of your bicycle's components is essential.

### KEEP YOUR BIKE CLEAN

Routinely wash your bicycle using gentle soap and water to maintain its optimal performance and inspect the frame and its parts for any wear. Avoid high-pressure water, as it may harm elements such as bearings, electrical components, or frame tubing. Biodegradable degreasers made from citrus are highly effective at eliminating grease from the chain and drivetrain components.



Accumulated dirt can make it harder to visually inspect components, potentially concealing damage that may lead to malfunctions or accidents.



Accumulated dirt leads to early wear of components and may even damage parts of the bicycle frame, like bearing housings and moving parts. Any damage resulting from neglecting cleaning and maintenance is not covered by the warranty.

### KEEP YOUR DRIVETRAIN LUBRICATED

After cleaning your bicycle, apply lubricant to the drivetrain, focusing on the chain. Use only the necessary amount to coat the links, wiping off any excess to avoid attracting dirt, which could hinder performance and lead to premature component wear.



Avoid using aerosol lubricants to prevent them from contaminating the brake surfaces. Always inspect the brakes after applying lubricant to the drivetrain.

### INSPECT YOUR BICYCLE BEFORE EACH RIDE

Conduct a brief check before every ride to ensure your bike is in top condition. Minor issues could develop into serious problems while riding.

**FRAME:** Examine the frame and fork for cracks or other damage. No unusual sounds should be heard. If damage is found, do not ride the bike and contact your authorized dealer for an inspection.

**CHAIN:** Ensure it is clean and properly lubricated. The drivetrain should operate without any odd noises.

**BRAKES:** Verify that the brakes are functioning properly and safely. Also, check the tightness of the components.

**TIRES:** Inspect the tires for wear and check for any cuts on the tread or sides. Replace the tire if damaged. Ensure the tire pressure is appropriate.

**WHEELS:** Ensure the wheels spin smoothly and show no lateral movement. Gently pull the wheel sideways to check for any play in the bearings. Check for any broken or loose spokes. Confirm that the axles and quick-release skewers are securely tightened to the correct torque.

**HEADSET:** Apply the front brake and gently move the front of the bike back and forth, pressing on the handlebars with the front wheel on the ground. Look for unusual sounds or movement in the headset, which could indicate worn bearings or incorrect tightening. Once adjusted, ensure the headset rotates smoothly.

**REAR TRIANGLE PIVOT POINTS:** On full-suspension bikes, ensure the swingarm pivots rotate smoothly without any bearing play. Move the swingarm side to side and listen for any noise or play. If it's not functioning smoothly or shows signs of play, it could mean improper tightening or worn/damaged bearings.

**BEARINGS:** Bearings (such as those in the bottom bracket, swingarm pivot points, headset, wheels, etc.) are wear-prone components that should be regularly checked to ensure proper functioning.

Damaged bearings can cause harm to the parts they are installed in. Harsh weather conditions can accelerate bearing wear. Bearings with excessive play or that don't rotate smoothly should be replaced immediately. If you're unsure, seek advice from your authorized dealer.



Damage to components such as the frame, bicycle wheels, and others, resulting from neglecting maintenance or failing to replace bearings, is not covered by the warranty.

**ELECTRICAL SYSTEM:** Power on the bike and ensure the electrical system is functioning correctly. Confirm that electrical assistance is active and that all components are working, including the motor, display, assistance mode switch, and speed sensor. If the electrical assistance isn't working, inspect the connections between components and check the condition of the cables (replace any damaged cables or parts). Look for any issues in the electrical system. If the System Controller on the top tube or the display shows an error, you can use the DJI Avinox app via the simcard of the display to learn more about the error or warning code and follow the troubleshooting steps. If the electrical system still doesn't work after following the suggested steps, or if no user-accessible solution is available, take your bike to an authorized dealer for diagnosis and repair.

## 04 MAINTENANCE



**TIGHTENING TORQUES:** Always verify the tightening torques and install the components outlined in this manual according to the specified torque values. Adhere to the tightening torque guidelines for components from other manufacturers installed on your Unno bicycle. Failing to follow these specifications could result in component malfunction, accidents, or even fatal injuries.



Not following the guidelines provided in this manual and riding a bicycle that exhibits any of the symptoms mentioned above can lead to accidents and severe injuries.



Refer to the manuals for the DJI Avinox Drivetrain electrical components in the appendix at the end of this manual.

### MAINTENANCE PERIODS OF COMPONENTS



The maintenance intervals for components listed below are for guidance and can vary based on factors such as weather conditions (harsh conditions significantly shorten component lifespan and maintenance intervals), cleanliness of the bike and its parts (components with accumulated dirt wear out faster), and usage (more intensive use of the bike requires more frequent maintenance).

For components from other brands installed on Unno bicycles, you can find the recommended or required maintenance intervals on the manufacturer's website or by contacting the brand's distributor in your country.



Damage to components caused by not adhering to the recommended maintenance intervals may result in issues that are not covered by Unno or the manufacturer's warranty.



Not following the maintenance intervals may cause component damage, leading to malfunctions and potential accidents.

**HEADSET:** Check its functionality before each ride. Disassemble and inspect the bearings every 6 months of use.

**BOTTOM BRACKET:** Inspect its operation before every ride. Disassemble and check the bearings every 6 months of use.

**DRIVETRAIN:** Inspect its operation before every ride. Regularly check the chain wear every 500 km. A worn chain that exceeds the manufacturer's specifications must be replaced to avoid damage to other drivetrain components. Failure to follow the manufacturer's wear guidelines could require replacing additional drivetrain parts.

**WHEELS:** Inspect its operation before each ride. Disassemble and manually inspect the bearings and all components every 6 months.

**SHOCKS AND SUSPENSION FORKS:** Inspect its operation before each ride. Full inspection and maintenance every 125 hours of use or once a year (whichever comes first) by an authorized dealer.

**DROPPER SEATPOSTS:** Inspect its operation before every ride. Full inspection and maintenance every 125 hours of use or once a year (whichever comes first) by an authorized dealer.

**PIVOT POINTS ON FULL SUSPENSION FRAMES:** Inspect its operation before each ride. Disassemble the frame and manually inspect all bearings every 125 hours of use or once a year (whichever comes first). These intervals may be shorter depending on riding conditions. More demanding use or riding in adverse weather or mud requires disassembly and inspection every 75 hours of use or once every 6 months (whichever comes first). If any bearing does not rotate smoothly or has excessive play, it must be replaced immediately.

**GEAR CABLES AND HOUSING:** Inspect its operation before every ride. Replace the gear cables every 6 months to 1 year, depending on the bicycle's usage.

**BRAKES:** Inspect the operation and wear of brake pads or shoes before each ride. Check the wear on disc brakes and inspect the cables or hydraulic lines every 6 months to 1 year, based on usage conditions. Flush the hydraulic lines annually.

**ELECTRICAL ASSISTANCE SYSTEM COMPONENTS:** Regularly inspect the connections and cables of the electrical assistance system on your bike. Ensure that the connections are clean and free from debris. The cables must be in good condition, with no cuts or kinks that could cause short circuits or loss of electrical assistance. Ensure that components such as remote controls and batteries are free from external damage that could allow water or debris to enter. If any electrical component is damaged, visit your Unno dealer for diagnosis and possible replacement.



Refer to the manuals for the DJI Drive System electrical components in the appendix at the end of this document.

You can also check all the DJI component manuals at the following link:

[DJI Avinox Drive System - Download Center - DJI](#)

# 04 MAINTENANCE

Below is a summary of the maintenance schedule, outlining all key aspects of the process. For detailed information, please refer to the previous pages. If you have any questions regarding bicycle maintenance, we recommend visiting an authorized workshop or dealer. For further assistance, please contact us at:

[support@unno.com](mailto:support@unno.com)

SCHEDULE	BEFORE EACH RIDE	MONTHLY	3 MONTHS	6 MONTHS	ANNUALLY
CHECK TIRE PRESSURE	X				
CHECK BRAKE FUNCTION	X				
CLEAN AND LUBE CHAIN	X				
CLEAN BIKE OF MUD	X				
ENSURE ALL CABLE ENDS ARE COVERED WITH CRIMPED CABLE AND END C.	X				
CHECK HEADSET AND TIGHTEN/LOOSEN, IF NECESSARY		X			
CHECK FOR LOOSE BOLTS AND TIGHTEN, IF NECESSARY		X			
INSPECT CONNECTIONS AND CABLES OF THE ELECTRICAL COMPONENTS		X			
CHECK TIRES FOR WEAR			X		
CHECK SPOKE TENSION, IF NECESSARY			X		
CHECK CHAIN FOR WEAR, REPLACE IF NECESSARY			X		
CHECK / REPLACE BRAKE PADS			X		
CHECK AND INSPECT HEADSET BEARINGS				X	
CHECK AND INSPECT BOTTOM BRACKET BEARINGS				X	
CHECK AND INSPECT WHEEL BEARINGS				X	
CHECK AND INSPECT ALL THE BEARINGS OF LINKS				X	
INSPECT THE CABLES OR HYDRAULIC LINES				X	
CHECK THE WEAR ON DISC BRAKES				X	
FLUSH HIDRAULIC LINES					X
FULL INSPECTION AND MAINTENANCE OF DROPPER SEATPOSTS					X
FULL INSPECTION AND MAINTENANCE OF SHOCK AND FORK					X
COMPLETE TUNE-UP PERFORMED BY AN AUTHORIZED UNNO DEALER					X

## 04 MAINTENANCE

### UPDATES TO THE ELECTRICAL SYSTEM:

Ebike electrical assistance systems may receive improvements or updates that enhance the system's performance. Some updates to the DJI Drive System can be done via Bluetooth® by connecting your bike to the DJI app. The DJI app may not be available on the Google Play Store or Apple Store in countries where DJI does not offer after-sales service. In this case, updates must be performed by an authorized dealer using the DJI diagnostic tool. To explore all features of the DJI app, visit:

[Avinox - Download Center - DJI](#)

Other updates might require an authorized dealer's assistance. When bringing your bike in for maintenance or repairs, remind your dealer to check for any available updates

 Some of these inspections and maintenance tasks may exceed the mechanical expertise of most bicycle users. If you are not qualified to carry out the necessary maintenance, always visit an Unno dealer to ensure proper servicing of your bike and its components.

 Neglecting proper maintenance can lead to malfunctions and accidents with serious consequences..

 Improperly performed maintenance can cause damage to components, which will not be covered by the warranty.

### SPARE PARTS

Always use original Unno or DJI spare parts or those of the manufacturer of the component in question.

 Using non-original spare parts may cause damage, leading to malfunctions and accidents with serious consequences.

 Installing many of the parts listed in this technical manual requires mechanical expertise beyond that of most bicycle users. If you are not qualified to install these components, always visit an Unno dealer for proper maintenance. Incorrect installation of spare parts can lead to malfunctions, accidents, and serious injuries.

 Installing non-original spare parts may cause damage to your bicycle, which will not be covered by the warranty.

### AFTER AN IMPACT OR A CRASH

Falling off a bike is an inherent risk of cycling. If you have an accident while riding your Unno bicycle, first ensure that you are uninjured and seek medical attention if necessary. If you are unharmed, inspect your bike before continuing to ride.

#### INSPECT THE FRAME AND COMPONENTS FOR DAMAGE

If you notice any issues, do not continue riding the bicycle.

#### POINTS TO CHECK:

- Examine the frame and fork for any signs of breakage or bending.
- If you find cracks or damage, stop using the bicycle immediately.

For carbon frames, check for cracks or soft spots in the material. If you notice any of these signs, stop using the bicycle immediately

 Carbon frames and forks are made from rigid and strong materials, but under excessive load or impact, the fibers do not bend—they break. A strong enough impact may cause hidden damage that is not immediately visible but could lead to material failure over time. If you are unsure about the effects of a fall or accident, consult your Unno distributor for a proper assessment of the materials.

Inspect the drivetrain and wheels to ensure all components function properly. If you find any damage, stop using the bicycle immediately. Even if no visible damage is present, listen carefully to your bike when riding again. Breakages or other issues can cause unusual noises. If you hear any abnormal sounds, stop using the bicycle right away and contact your Unno dealer for a proper diagnosis.

### TAKE YOUR UNNO BICYCLE TO AN AUTHORISED DEALER FOR A PROFESSIONAL INSPECTION

Certain consequences of a fall or accident can only be identified by fully disassembling the bicycle to look for cracks or other signs of damage.

 A crash or impact can inflict significant damage to your bicycle and its components, leading to premature failure or wear. Failures may happen unexpectedly, causing loss of control, serious injury, or even death.

## 05 USE WARNINGS

### MAXIMUM TIRE WIDTH

This technical manual specifies the maximum tire size that can be installed on the frame. Always follow these guidelines when fitting tires on your bicycle. However, the actual measurements of tire circumference and width may vary between manufacturers. When installing a tire different from the one originally mounted on your Unno bicycle, ensure there is at least 8 mm of clearance between the top and sides of the tire and any part of the frame or fork.

**i** Damage to the frame or components caused by using a tire that does not meet these specifications is not covered by the warranty.

### MINIMUM SEATPOST INSERTION LENGTH

**!** Always adhere to the minimum insertion depth specified for the seatpost or frame on racing bikes by the various seatpost manufacturers. Failure to adhere to these guidelines may put excessive stress on the materials, resulting in breakage not covered by the warranty, as well as accidents that can cause serious injury.

### MAXIMUM FORK LENGTH (AXLE TO CROWN)

Always adhere to the maximum fork length specified in the technical specifications section of this manual. The maximum fork length refers to the distance from the fork axle to the bottom part of the head tube (axle to crown).

**!** Failing to follow this requirement and installing forks longer than the maximum specified can stress the frame beyond its designed limits, potentially causing material malfunctions that could lead to accidents and serious injuries.

**i** The Unno Mith is not compatible with double crown forks. Damage caused by using non-compatible components is not covered by the warranty.

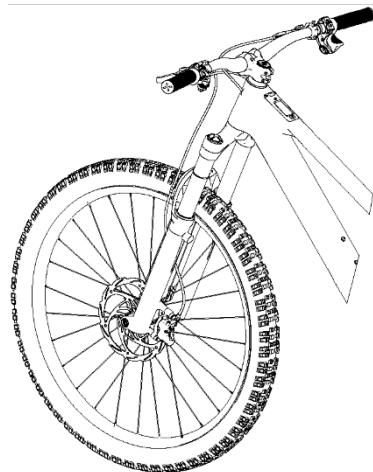

### INTENDED USE

According to the international standard ASTM F2043, the intended use of bikes is divided into five different categories, ranging from the use on paved roads through to downhill or freeride use.

The Unno MITH is a category 4 all mountain bike:

#### CATEGORY 4: FOR USE IN ROUGH TERRAIN AND FOR JUMPS OF UP TO 122 CM:

Category 4 includes the use of bikes and their components under the conditions of categories 1,2 and 3 as well as in very rough and partially blocked terrain with steeper sections and higher speeds. Regular, moderate jumps pose no problem for experienced riders when using these bikes. Extended and regular use in bike parks and when tackling “North Shore” sections should be avoided. Due to increased stresses, these bikes should be checked for damage after every ride. Full suspension bikes with mid-level travel are typical in this category.



Please check the weight limit before using. The maximum payload, which stands for the maximum rider weight with equipment, is the following:

Unno MITH: 120kg/275lb

### SERIAL NUMBER OF YOUR BIKE

The serial number of your frame is located in the bottom bracket. Always use this serial number when communicating issues to UNNO.

Your serial number should look like this: **UNVV00A0000**



# 06 WARNINGS REGARDING THE USE OF ELECTRIC SYSTEM

## CLEANING DRIVE SYSTEM

The interval for upkeep depends on the terrain and usage conditions. Always power off the battery and securely seal the charging and Type-C ports before washing. Wipe off any dust or grime with a gentle, dry fabric. If needed, employ a damp cloth with a mild cleanser for thorough cleaning.

 Incorrect cleaning methods can result in harm to electronic parts

Wipe the Type-C port with a soft, dry cloth or tissue if it contains any liquid or debris.

 Avoid using high-pressure water sprays on the motor, battery, or any electrical parts, as this could lead to fire hazards.

 Keep electrical component interfaces away from liquids. Ensure they are completely dry before connecting to avoid potential damage.

## BATTERY MAINTENANCE

Store the battery in a cool, dry place away from direct sunlight, maintaining a temperature between 0° and 40°C (32° to 104°F).

Routinely monitor battery levels and cycle counts. After 500 cycles, battery capacity may decrease, but this will not affect riding performance.

If the battery level drops below 10%, recharge it promptly to prevent reduced battery lifespan.

Long periods of inactivity can impact battery performance. To maintain its condition, fully discharge and recharge the battery every three months.

 Cease use immediately if the charging port or cable shows any signs of wear or damage.

Unplug the battery from the charger once it's fully charged. Avoid overcharging, as it may damage the battery cells.

Charging the battery at high temperatures may shorten its lifespan. After each ride, let the battery cool to room temperature before charging. Charging between 0° to 40°C (32° to 104°F) can significantly prolong its life.

When storing the battery for a long period, remove it from the frame and keep it out of children's reach.

For long-term storage, it's recommended to discharge the battery to 30%. Storing it with a full charge can reduce its lifespan, while storing it with too little charge may cause over-discharge.

Before transporting, discharge the battery to around 30% and remove it from the frame to prevent it from falling or damaging the connectors. Always use a carrying case for transportation and avoid transporting a damaged battery.

You can also access all the DJI Avinox component manuals at the following link:

[DJI Avinox Drive System - Download Center - DJI](#)

## RANGE

The available range per charge is influenced by several factors, including:

**Assistance mode:** Higher assistance levels will reduce the available range.

**Customising assistance modes:** Adjusting the power delivery of different levels via the DJI app can impact the range per charge.

**Temperature:** Charging and using the battery in low temperatures will decrease the range.

**Weight of the cyclist and equipment/luggage.**

**Cyclist's pedaling effort.**

**Terrain and slopes:** Riding on rough terrain or uphill will reduce the range.

**Frequent stops and starts** can also affect the available range.

## TRANSPORT OF ELECTRIC BATTERIES

Batteries must be transported in accordance with current regulations and the allowed transport methods for these items. Always use the original approved packaging and an authorised carrier for transportation or shipping. Check the handling and transport requirements for this type of item in your country. If the batteries need to be sent to DJI or Unno for repair or diagnosis, they must be packed in the original approved packaging and shipped using an authorised carrier. DJI or Unno can guide you on the best option. If you require battery safety documentation (MSDS) for transportation or if the shipping company requests it, contact DJI or Unno for assistance in providing the necessary documentation.

## TRANSPORT OF E-BIKES

If you plan to travel with your electric bike, check the battery transportation policies of the airline you intend to use. Most commercial airlines do not allow the transport of batteries with a capacity greater than 100Wh.

# 07 USE OF THE DJI AVINOX DRIVE SYSTEM

**i** This section explains the basic operation of the DJI Avinox Smart System electrical system in Mith. Refer to the manuals of all the components of the Smart System in the appendix of this manual for detailed instructions on using the system's components. You can also access all the DJI Avinox component manuals at the following link:

<https://www.dji.com/es/downloads/products/avinox#doc>

## CONTROL DISPLAY AND WIRELESS CONTROLLERS

**!** Be sure to familiarize yourself with the functions and operations of the control display and wireless controllers before riding the bike.

### BUTTON FEATURES

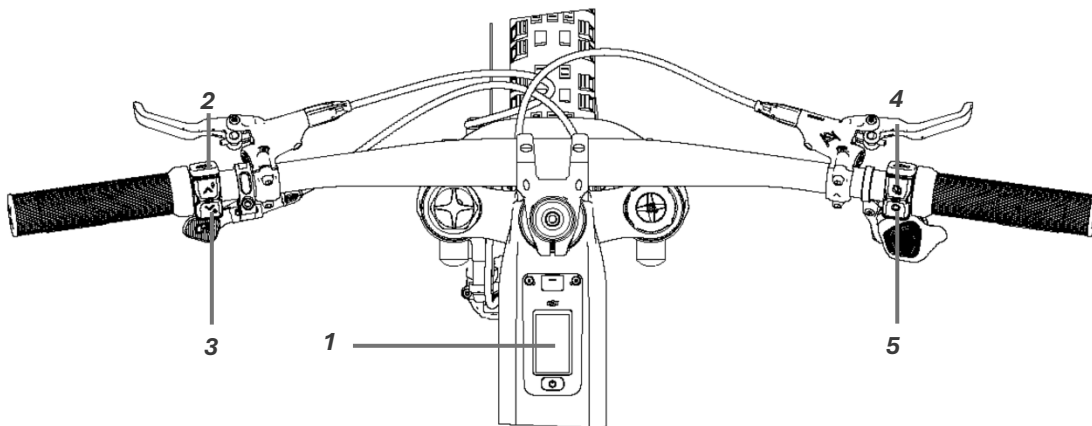

#### 1. POWER BUTTON

Press and hold to turn the power on/off. To force a power off, press and hold for 20 seconds. When powering on for the first time, follow the on-screen prompts to select your language and activate the system.

After powering on, press to toggle between the assist modes: Off, Auto, Eco, Trail, and Turbo.

#### 2. ASSISTANCE LEVEL INCREASE BUTTON

Press to cycle through the assist modes in this order: Off > Auto > Eco > Trail > Turbo.

Press and hold to activate Boost mode, and the bike screen will show a countdown. Press the power/increase/decrease buttons to exit Boost mode.

#### 3. ASSISTANCE LEVEL DECREASE BUTTON

Press to cycle through the assist modes in this order: Turbo > Trail > Eco > Auto > Off

Press and hold, then release the button to activate Walk mode. Once activated, press and hold the button to receive power assistance for pushing the bike uphill. Press any other button to exit Walk mode.

#### 4. SCREEN SWITCH BUTTON (CUSTOMIZABLE)

Press to slide the bike screen to the right.

Swipe up on the bike screen to access Settings, where you can customize the button functions under Customize Controls.

#### 5. FUNCTION BUTTON (CUSTOMIZABLE)

Press to slide the bike screen to the left. When on the Settings page, press to return to the previous page.

Swipe up on the bike screen to open Settings, where you can customize button functions under **Customize Controls**

#### REPLACING BATTERY OF CONTROLLER

For the process on how to change the battery of the controllers please refer to the DJI user manual. You can access the manual at the link shown at the top of this manual section.

#### OPERATING THE CONTROL DISPLAY

Once the control display is powered on, the home screen will appear. Tap or swipe on the screen to interact with the display.

**Home Screen:** Displays basic information.

**Swipe left/right** to navigate to the ride data pages, which can be customized through the app.

**Swipe Up:** Access Settings to add accessories, configure the recording mode, and make other adjustments.

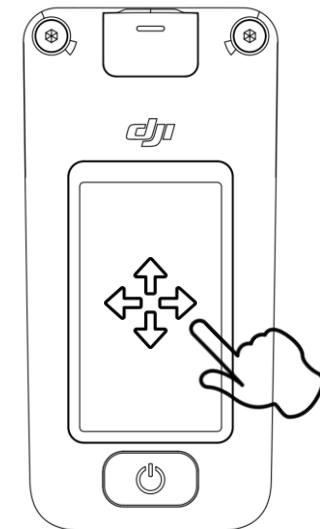

# 07 USE OF THE DJI AVINOX DRIVE SYSTEM

## PAIR AND ACTIVATE

When powered on for the first time, follow the on-screen prompts to complete pairing and activation. Tap "Skip" to ride for a trial without activation. After the trial distance is exhausted, follow the steps below to pair and activate the system before continuing use.

1. Press and hold the power button on the control display to turn it on.
2. Swipe up on the screen to access Settings, then tap **"Pair to App"** to display the QR code.
3. Ensure Bluetooth and network are enabled on your mobile device. Open the Avinox app, tap **"Pair"**, and scan the QR code to complete the pairing process.

## DEVICE UPDATES

When connected to the drive system, the app will prompt you if a version update is available. It's recommended to update to the latest version for an improved user experience.

Ensure sufficient battery power before starting the update. During the update, make sure your phone has a strong signal and that the Bluetooth connection remains stable. Do not move the bike or power off the control display while updating.

## CHARGING THE BATTERY



Ensure you use the official charger to charge the battery. While charging, make sure not to move the bike and place the charger on a flat, stable surface.

1. Open the charging port cover and connect the charger.
2. While charging, the bike screen will show the current battery level.
3. Unplug the charger and close the port cover once the battery is fully charged. Avoid pulling the power cable forcefully when disconnecting the charger.

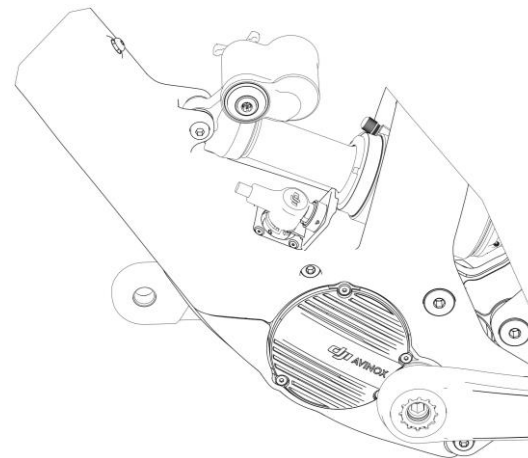

## IDENTIFY THE CHARGE LEVEL OF THE BATTERY

- Red: The battery is charging
- Green: Fully charged
- Yellow: The charger is connected incorrectly or there is an issue with the connection

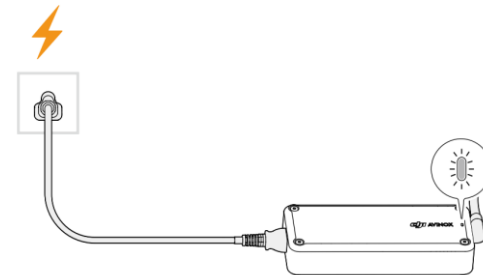

## CHARGING EXTERNAL DEVICES

Use the USB-C cable to connect the control display to an external device, then power on the control display to charge the connected device.

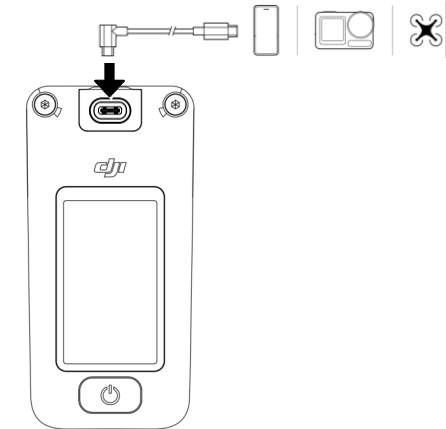

## AVINOX APP

When the drive system is paired with the Avinox App via Bluetooth, users can customize assist parameters, adjust the bike screen, and enable bike protection features in the app. After inserting a SIM card into the control display, users can remotely control the bike through the app.

[Avinox - Download Center - DJI](#)

For detailed information on the benefits of using the SIM card and instructions on how to install it, please refer to the DJI Avinox manual available at the following link.

[DJI Avinox Drive System - Download Center - DJI](#)

# 08 GEOMETRY AND SIZING

SIZE	S1	S2	S3
A Top Tube Horizontal	574,13	606,82	642
B Seat Tube Length (Frame)	400	420	440
C Seat Tube Length (BB-Saddle)	725	725	725
D Real Seat Tube Angle (°)	75,25	75,25	75,25
E Virtual Seat Tube Angle (°)	77	77	77
F Head Tube Length	107	120	145
G Head Tube Angle (°)	63,5	63,5	63,5
H Chainstay Length horizontal	450	450	465

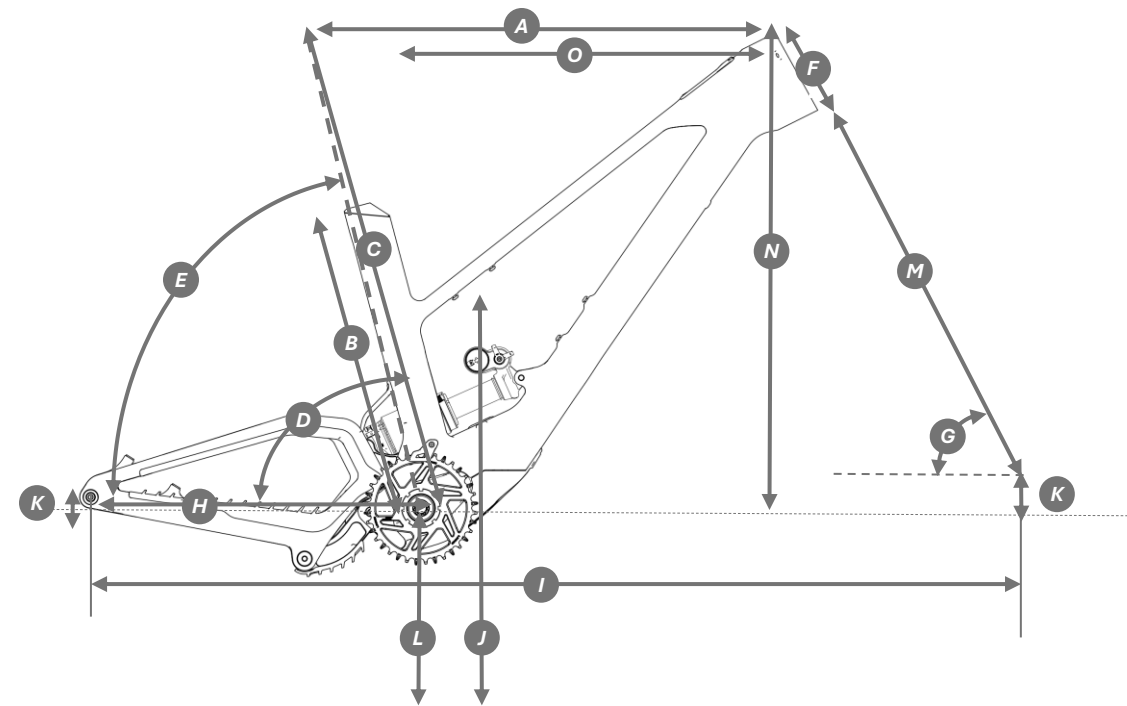

## SIZING TABLE

HEIGHT	155	160	165	170	175	180	185	190	195	200
S1	████████████████████									
S2		██								
S3			██							

The measurements in the sizing table are for reference only. The best way to determine your correct frame size is to test a bike at one of our authorized dealers.

# 08 GEOMETRY AND SIZING

## MAXIMUM AND MINIMUM SEAT HEIGHTS WITH DROPPER SEATPOST

The table below displays the highest and lowest seat heights when the dropper seatpost is fully extended for each frame size.

The maximum seat height corresponds to the saddle position when the seatpost is inserted at its minimum depth, as determined by the seatpost itself. The minimum seat height is measured when the seatpost is inserted at its maximum depth, as dictated by the frame.

These height values apply only to the dropper seatpost and saddle configurations installed by Unno for a specific frame. If using a different dropper seatpost, refer to the manufacturer's specifications and check the maximum frame insertion limits in the technical specifications section of this manual.

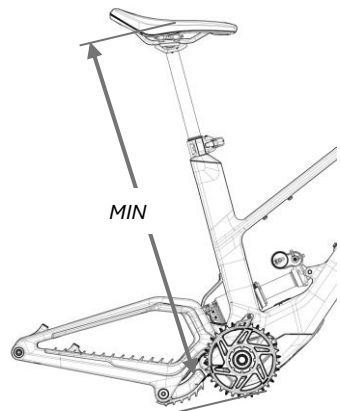

**i** The measurements in the table below indicate the distance from the center of the bottom bracket shell to the midpoint of the upper section of the saddle (for saddles installed by Unno). Various saddle models on the market can affect these measurements by approximately ±5 mm, depending on their height. If your seat height varies by less than 5 mm from the listed value, you can adjust it by selecting an alternative saddle model. If the difference exceeds 5 mm, it is advisable to opt for a dropper seatpost with a different travel length to achieve the appropriate fit.

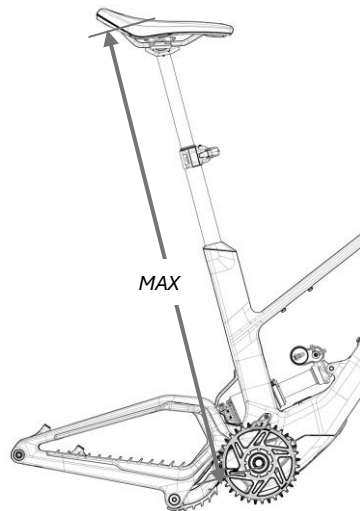

Minimum Extended Height (BB to Saddle top in mm)				
Models	Seatpost travel	S1	S2	S3
Fox Transfer Neo 2025-26	100	547	567	587
	125	572	592	612
	150	655	657	637
	175	712	714	713
RS Reverb Stealth 2025	200	767	769	768
	100	550	570	590
	125	575	595	615
	150	663	665	640
ONEUP V3	175	716	718	717
	200	768	770	769
	120	550	570	590
	150	622	600	620
X-FUSION MY22 MANIC	180	687	689	688
	210	752	754	753
	100	550	570	590
	125	575	595	615
RS Reverb AXS 2.0	150	670	672	640
	170	714	716	715
	100	563	583	603
	125	588	608	628
RS Reverb AXS	150	655	633	653
	175	705	707	678
	200	755	757	756
	100	565	585	605
RS Reverb AXS	125	590	610	630
	150	670	635	655
	175	710	712	675
	200	880	900	920

Maximum Extended Height (BB to Saddle top in mm)				
Models	Seatpost travel	S1	S2	S3
Fox Transfer Neo 2025-26	100	668	688	708
	125	703	723	743
	150	758	778	798
	175	815	835	855
RS Reverb Stealth 2025	200	820	840	860
	100	659	679	699
	125	709	729	749
	150	772	792	812
ONEUP V3	175	825	845	865
	200	877	897	917
	120	688	708	728
	150	738	758	778
X-FUSION MY22 MANIC	180	788	808	828
	210	838	858	878
	100	668	688	708
	125	709	729	749
RS Reverb AXS 2.0	150	763	783	803
	170	777	797	817
	100	695	715	735
	125	745	765	785
RS Reverb AXS	150	795	815	835
	175	845	865	885
	200	865	885	905
	100	698	718	738
RS Reverb AXS	125	748	768	788
	150	798	818	838
	175	838	858	878
	200	918	938	958

# 09 TECHNICAL SPECS

<b>FRAME MATERIAL</b>	
FRONT TRIANGLE	Carbon
SWINGARM	Carbon
TOP LINK	AL 7075 - T6
LOWER LINK	AL 7075 - T6
RECOMMENDED USE	All Mountain. ASTM Condition 4
SIZES	S, M, L
SUSPENSION DESIGN	Dual Pivot
FORK TRAVEL	170mm
MAXIMUM FORK LENGTH (AXLE-TO-CROWN)	576 mm
FORK OFFSET	44
COMPATIBLE WITH DOUBLE CROWN FORK	No
REAR TRAVEL	165 mm
SHOCK DIMENSIONS	Metric. Standard 230 x 65 mm
SHOCK HARDWARE	Metric. 20 x 8 mm
LINKAGE	See top link and lower link sections
FRAME	See top link and lower link sections
RECOMMENDED SAG	SAG STD 19.5mm // RACE 22.5 mm
HEADSET	Cane Creek 40-ASMBLY-TPR-IS41/28.6/H9   IS52/40
HEADSET BEARINGS	Top: IS41 / 28.6 H9mm
	Bottom: IS52 / 40
HEADSET SPACERS	See Headset and Stem sections
MAXIMUM HEADSET SPACERS	30mm
STEM	See Stem section
BOTTOM BRACKET	DJI Avinox Drive System
CHAINLINE	55 mm

<b>MITH DJI</b>	
WHEEL SIZE	Front 29" / Rear 27.5"
MAXIMUM REAR TYRE WIDTH	2.6
MAXIMUM FRONT TYRE WIDTH	Depends on the fork (Fox 38: 2.6") (Rockshox 35: 2.6")
DJI AVINOX SPEED SENSOR MAGNET INSTALLATION	Installation of speedsensor on swingarm
REAR AXLE STANDARD	Boost 12 x 148
REAR AXLE MEASUREMENTS	12 x 183 mm
REAR AXLE THREAD PITCH	1.0 mm
REAR AXLE THREAD LENGTH	13 mm
SEATPOST DIAMETER	31.6 mm
SEATPOST CLAMP	See seatpost section
<b>MAXIMUM SEATPOST INSERTION</b>	
S	315 mm
M	263 mm
L	214 mm
DROPPER SEATPOST COMPATIBLE WITH INTERNAL CABLING	Yes
FRONT DERAILLEUR	No. Single chainring only
COMPATIBLE CHAINRINGS	Chainrings for DJI Avinox Drive System. Unno Custom and E13
MAX SIZE. CHAINRING	36T
MINIMUM SIZE OF CHAINRING	32T
COMPATIBLE WITH OVAL CHAINRING	No
COMPATIBLE CRANKS	Cranks for DJI Avinox Drive System. Maximum length 170mm
BRAKE TYPE	Disc
REAR BRAKE CALIPER STANDARD	Post Mount
MAXIMUM REAR DISC SIZE	220 mm
MINIMUM REAR DISC SIZE	200 mm

# 09 TECHNICAL SPECS

	MITH DJI
MINIMUM FRONT DISC SIZE	FOX 38: 180mm
MAXIMUM FRONT DISC SIZE	FOX 38: 220 mm
COMPATIBLE CHAINGUIDE	No. Only works Unno Custom chainguide
ICGS	No
CABLE ROUTING	<b>Rear derailleur and rear brake:</b> Internal through headtube, downtube and chainstays
	<b>Front brake:</b> External
	<b>Dropper Seatpost:</b> Internal through headtube, downtube and seattube
	<b>Ebike system:</b> All internal cabling Speedsensor through chainstay
COMPATIBLE REAR LEFT BRAKE CABLING	No
BOTTLE HOLDER	1.On all sizes. Fitted to downtube
TRANSMISSION COMPATIBILITY	SRAM 11V and 12V. MTB
EBIKE SYSTEM COMPATIBILITY	DJI Avinox Drive System only
INTERNAL EBIKE BATTERY COMPATIBILITY	DJI Avinox 800Wh and 600 Wh
COMPATIBLE SHIMANO Di2	No
COMPATIBLE SRAM AXS	Yes
SRAM AXS T-TYPE COMPATIBLE	Yes
POWERMETER COMPATIBLE	No
TRAILER COMPATIBLE	No
REAR RACK COMPATIBLE	No
MUDGUARD COMPATIBLE	Yes. Only Unno custom
CHILD SEAT COMPATIBLE	No
RECOMMENDED MAXIMUM WEIGHT (rider)	125 kg / 275 lb

## TECHNICAL SPECIFICATIONS. DJI Avinox Drive System

 Check the full technical details of every component in the DJI Avinox Drive System through their manuals, which are included in this manual's appendix. Additionally, you can access all DJI Avinox component manuals at the following link.

[DJI Avinox Drive System - Download Center - DJI](#)

## DRIVE UNIT SPECIFICATIONS

CONTINUOUS RATED POWER	250W
MAXIMUM DRIVE TORQUE	105 Nm (Normal); 120 Nm (Boost)
TORQUE DENSITY	42 Nm/kg
MAXIMUM CADENCE	150 rpm
PROTECTION RATING	IP66
WEIGHT	2,52 kg Approx

Not all disc and caliper models are compatible with the frames. All Unno-specified assemblies are verified. For aftermarket options, check dimensions and tolerances before buying, or consult an Unno dealer.

# 09 TECHNICAL SPECS

BATTERY SPECIFICATIONS	800 Wh	600 Wh
BATTERY TYPE	Li-ion	Li-ion
VOLTAGE	35.9 V	35.9 V
PROTECTION RATING	IP56	IP56
CAPACITY	22.3 Ah	16.7 Ah
ENERGY	800 Wh	600 Wh
CHARGING TIME	<b>168 W charger</b> approx. 5h 50 min (0-100%) approx. 4h 28 min (0-75%)	<b>168 W charger</b> approx. 4h 45 min (0-100%) approx. 3h 3 min (0-75%)
	<b>508 W charger</b> approx. 2h 25 min (0-100%) approx. 1h 30 min (0-75%)	<b>508 W charger</b> approx. 2h 25 min (0-100%) approx. 1h 30 min (0-75%)
WEIGHT	Approx. 3.74 kg	Approx. 2.87 kg

## CONTROL DISPLAY SPECIFICATIONS

SCREEN	2.0-inch OLED 326 ppi 800 nit
EXPANSION PORT	12V 2.0A 24W
4G LTE	LTE-Cat.1
BLUETOOTH	BLE 5.1
POWER OUTPUT PORT	USB-C PD3.0 65W
GNSS	GPS + Galileo + BeiDou + GLONASS + QZSS
SENSING SYSTEM	Built-in IMU, barometer. Compass, ambient light sensor torque / cadence / wheel speed sensors
STORAGE CAPACITY	8 GB
PROTECTION RATING	IP56

## WIRELESS CONTROLLERS SPECIFICATIONS

BLUETOOTH	BLE 5.1
BATTERY	CR1620
PROTECTION RATING	IP56



# COMPONENTS. EXPLODED VIEWS, ASSEMBLY, USE AND SPARE PARTS

## 10 HEADSET

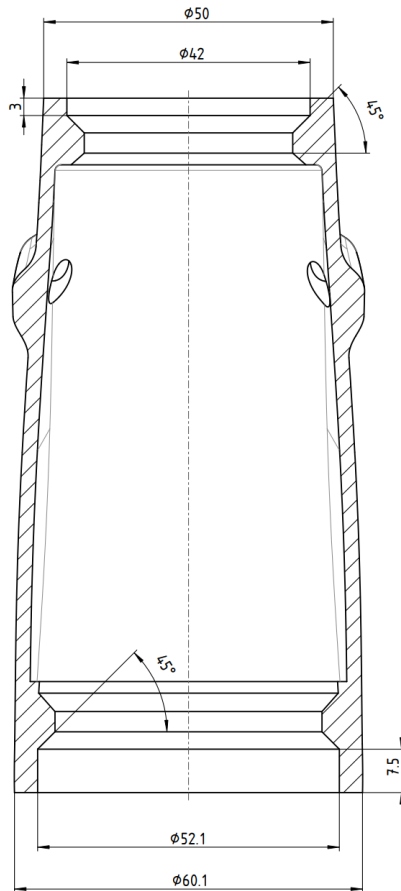

### HEADSET SPECIFICATIONS MITH 2025

	TYPE	ID	OD	HEADSET RACE ANGLE	PRELOAD RING / FORK CROWN RACE ANGLE	SHIS CODE	BEARING CODE CANE CREEK	BEARING DIMENSIONS
<b>TOP</b>	Integrated Bearing	30.15 mm	41 mm	$45^\circ$	$45^\circ$	IS41 / 28.6 / H9	BAA0741K	41 x 30.15 x 6.5 mm
<b>BOTTOM</b>	Integrated Bearing	40 mm	52mm	$45^\circ$	$45^\circ$	IS52 / 40		52 x 40 x 6.5 mm

\*ID: Internal diameter. \*\*OD: Outside diameter

**HEADSET EXPLODED VIEW AND ASSEMBLY**

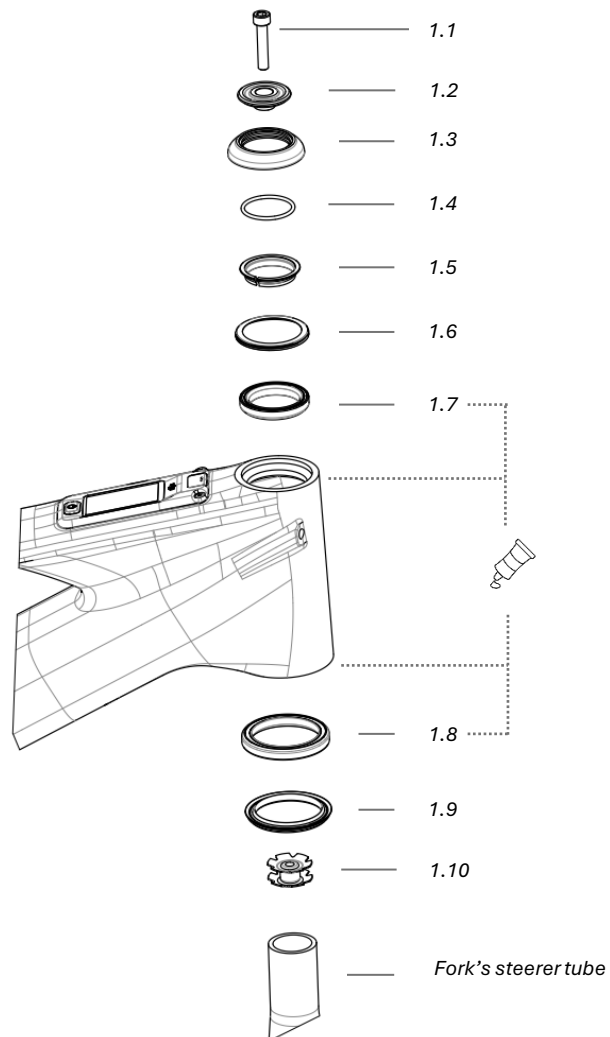

**HEADSET COMPONENTS**

**01 CANE CREEK 40-ASMBLY-TPR-IS41/28.6/H9 | IS52/40**

PART NO: BAA0741K

QUANT.







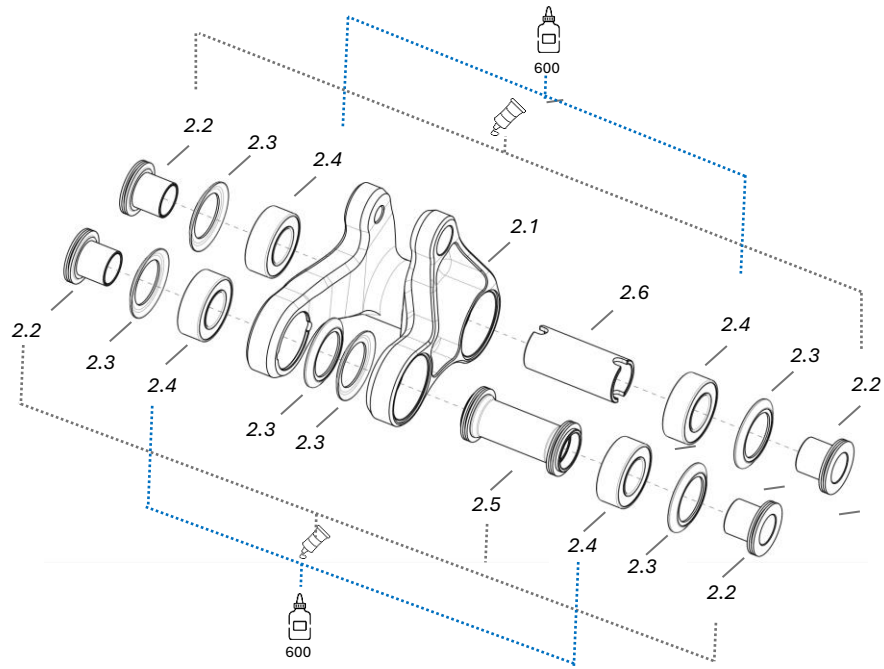

<b>1.1</b> Preload Bolt M6x1 30mm	1
<b>1.2</b> Top cap grooved 40 Series	1
<b>1.3</b> Top Cover IS41 Top 40 Series	1
<b>1.4</b> O-Ring - Headsets 28x2 IS 41 40 Series	1
<b>1.5</b> Compression Ring PL IS41 40 Series	1
<b>1.6</b> Seal Overmolded IS41 40 Series	1
<b>1.7</b> Bearing Platform IS41 40 Series	1
<b>1.8</b> Bearing Platform IS52 40 Series	1
<b>1.9</b> Crown Race Platform IS 52 40 Series	1
<b>1.10</b> Star Nut 125 Inch	1

# 11 TOP LINK







## 02 TOP LINK PREASSEMBLY

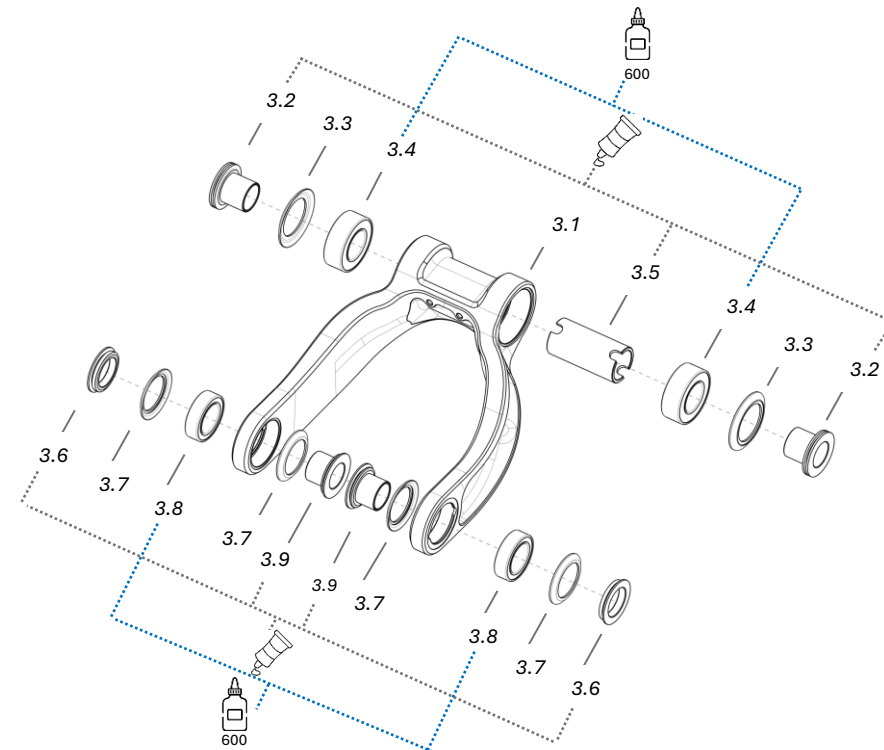



			QUANT.
	<b>2.1 TOP LINK</b>	HU27-TL-000	1
	<b>2.2 SPACER 01</b>	HU20-014	4
	<b>2.3 SPACER RUBBER D28</b>	HU20-003	6
	<b>2.4 BEARING 3802 OD28 ID15 T10</b>	3902_LLU_MAX	4
	<b>2.5 TOP LINK SLEEVE SPACER</b>	HU20-002	1
	<b>2.6 TOP LINK - RT SLEEVE SPACER</b>	HU20-007	1

# 12 LOWER LINK



## 03 LOWER LINK PREASSEMBLY

			QUANT.
	<b>3.1 LOWER LINK</b>	HU27-LL-000	1
	<b>3.2 SPACER 01</b>	HU20-014	2
	<b>3.3 SPACER RUBBER D28</b>	HU20-003	2
	<b>3.4 BEARING 3802 OD28 ID15 T10</b>	3902_LLU_MAX	2
	<b>3.5 LOWER LINK - FT SLEEVE SPACER</b>	HU20-001	1







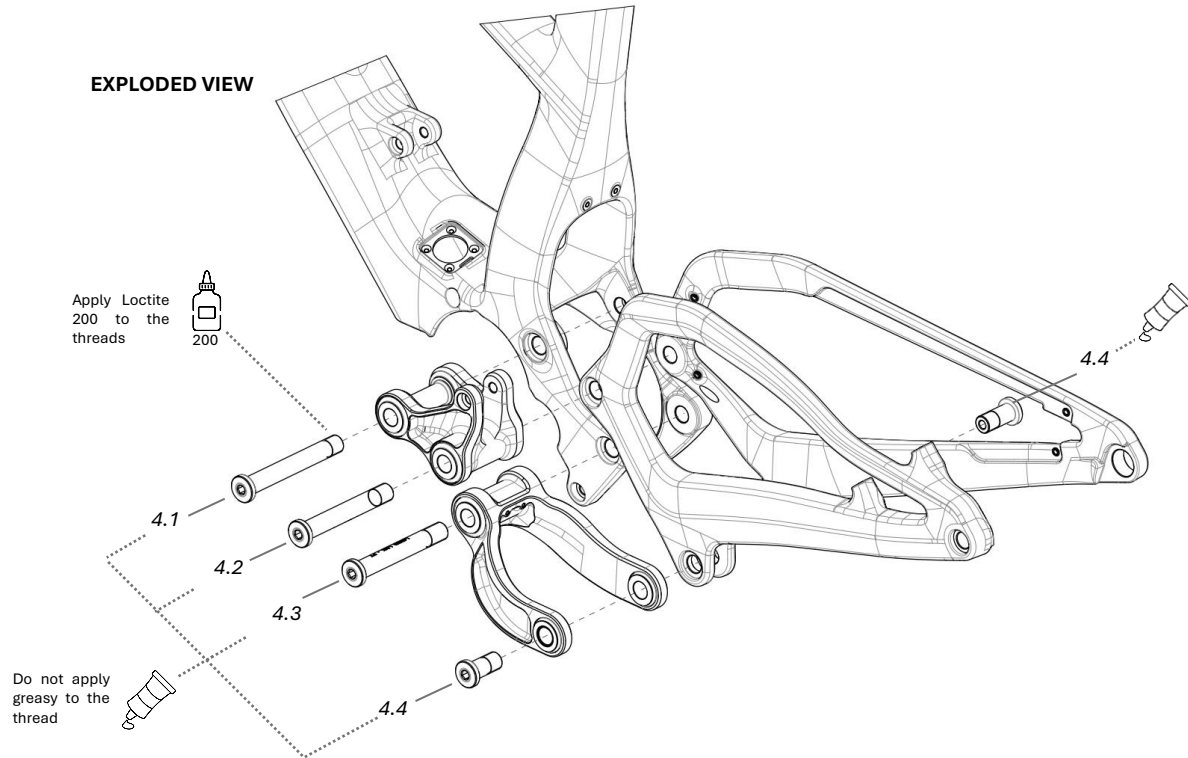

			QUANT.
	<b>3.6 LOWER LINK - RT SLEEVE SPACER</b>	HU20-015	2
	<b>3.7 SPACER RUBBER D24</b>	HU20-026	4
	<b>3.8 BEARING 3802 OD24 ID15 T7</b>	3802_LLU_MAX	2
	<b>3.9 SPACER 02</b>	HU20-025	2

# 13 PIVOT POINTS

EXPLODED VIEW





## 04 PIVOT POINTS

			QUANT.	TORQUE
	4.1 TOP LINK - FT AXLE	HU20-004	1	
	4.2 TOP LINK - RT AXLE	HU20-006	1	
	4.3 LOWER LINK - FT AXLE	HU27-012	1	
	4.4 LOWER LINK - RT AXLE	HU20-008	2	

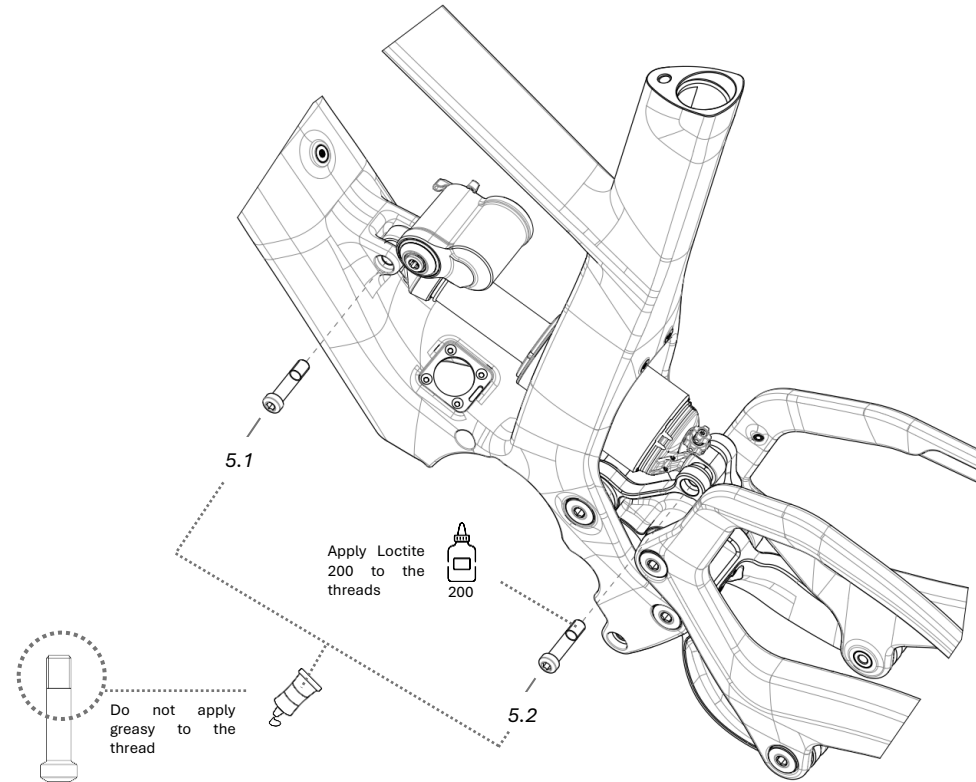
# 14 SHOCK - FRAME AXLE



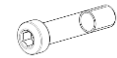

## 05 SHOCK - FRAME AXLE

			QUANT.	TORQUE
	5.1 SHOCK - FRAME AXLE	HU20-010	2	 15 Nm

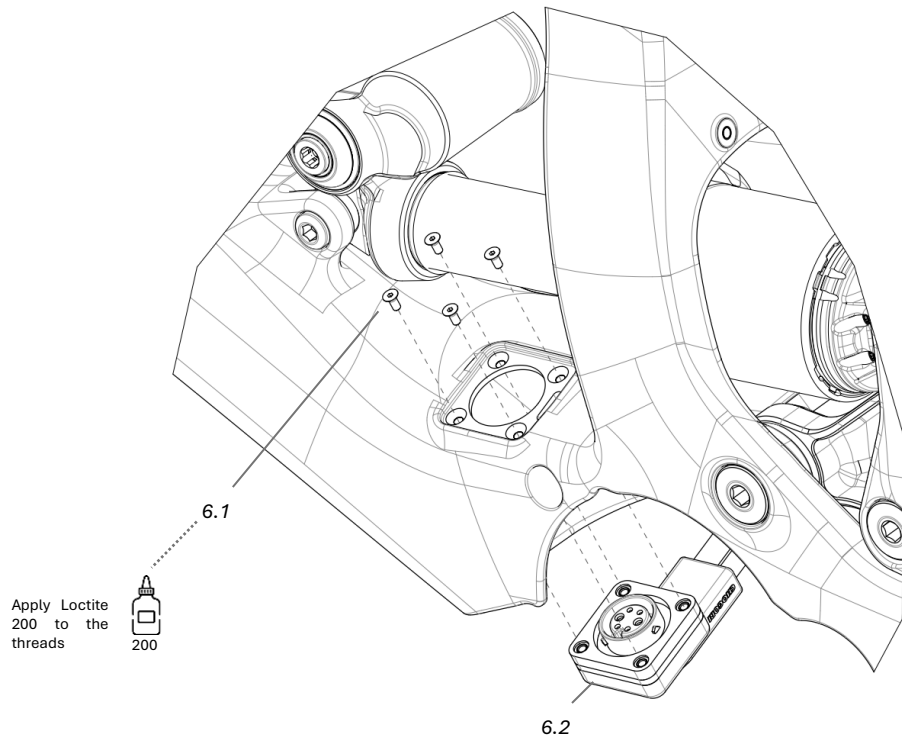
# 15 CHARGE PORT







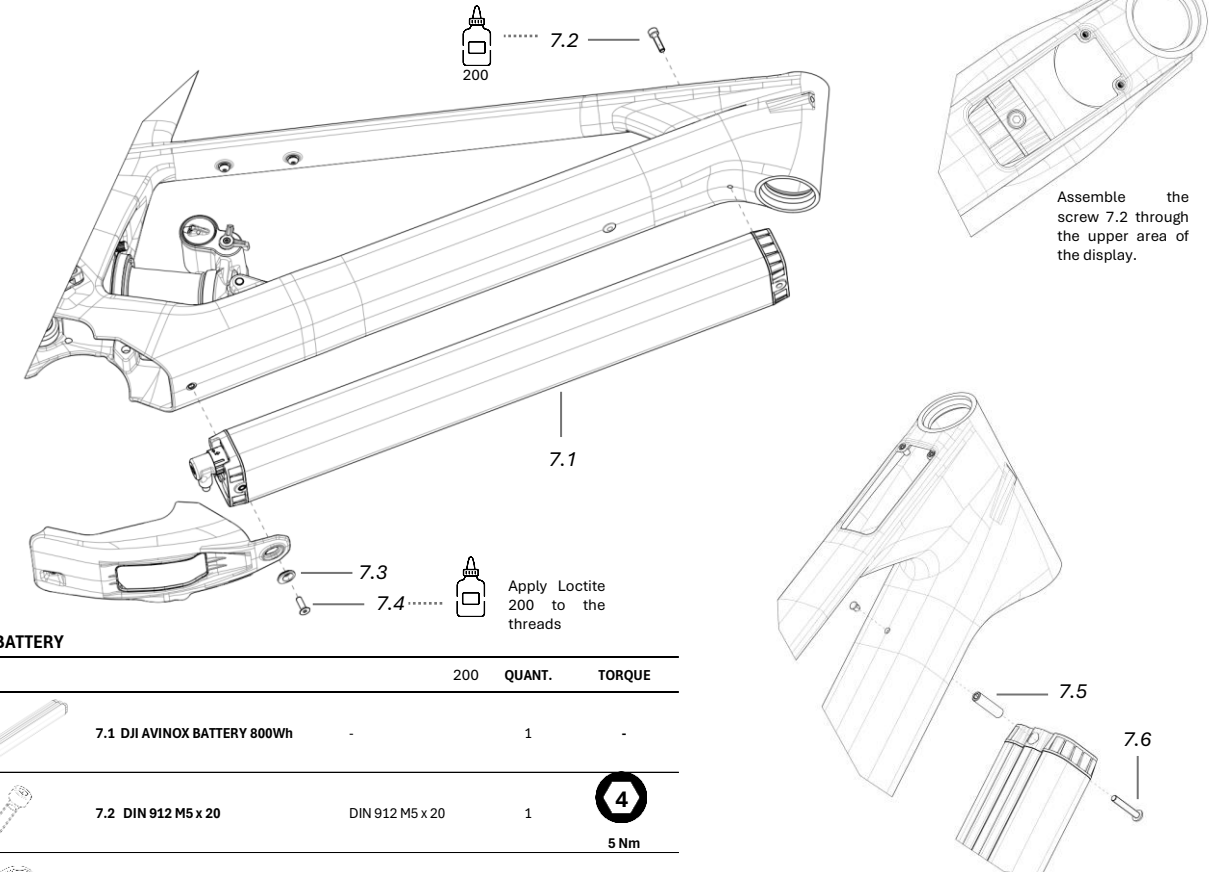

## 06 CHARGE PORT

			QUANT.	TORQUE
	6.1 DIN 7991 M2.5 x 6	DIN 7991 M2.5 x 6	4	<b>1.5</b> 1 Nm
	6.2 DJI AVINOX CHARGER PORT	Multiport Cable	1	-

# 16 BATTERY



## 07 BATTERY

			200 QUANT.	TORQUE
	7.1 DJI AVINOX BATTERY 800Wh	-	1	-
	7.2 DIN 912 M5 x 20	DIN 912 M5 x 20	1	<b>4</b> 5 Nm
	7.3 DU COVER SCREW ADAPTER M, L AND XL	HU27-014	1	-
	7.4 DIN 7991 M5 x 16	DIN 7991 M5 x 16	1	<b>3</b> 5 Nm
	7.5 800 BATTERY NUT SIZE L	HU27-009	1	-
	7.6 DIN 7380 M5 x 30	DIN 7380 M5 x 30	1	<b>3</b> 5 Nm



In size S3 the upper part of the battery is assembled to the frame by means of elements 7.5 and 7.6.

Assemble the screw 7.2 through the upper area of the display.



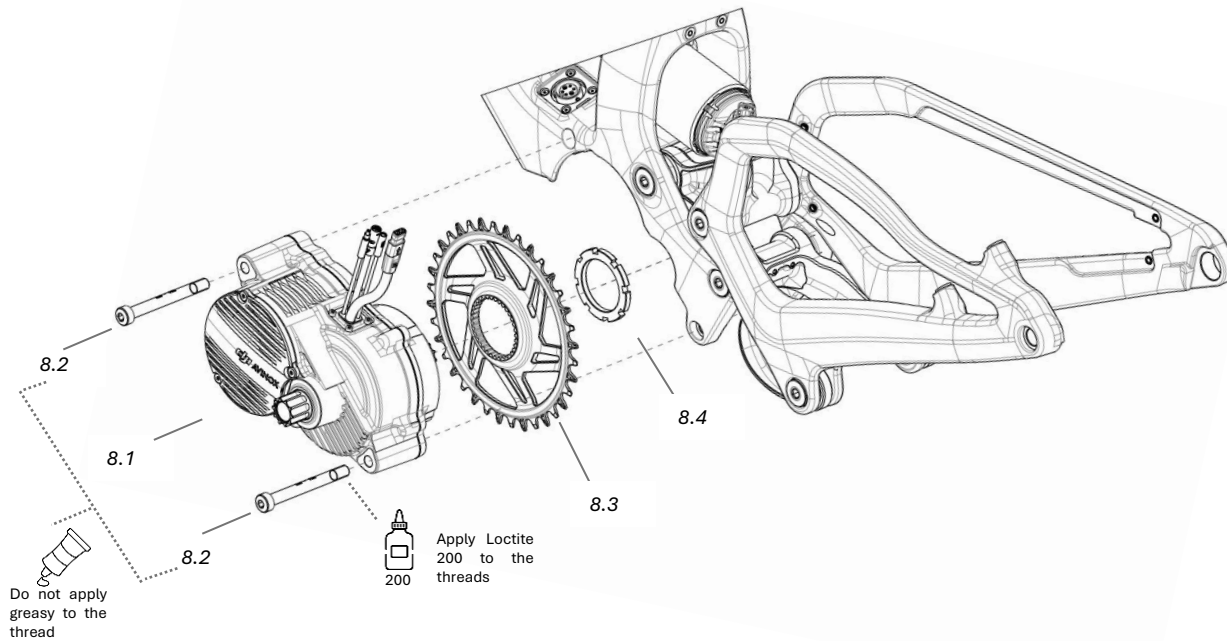

# 17 DRIVE UNIT

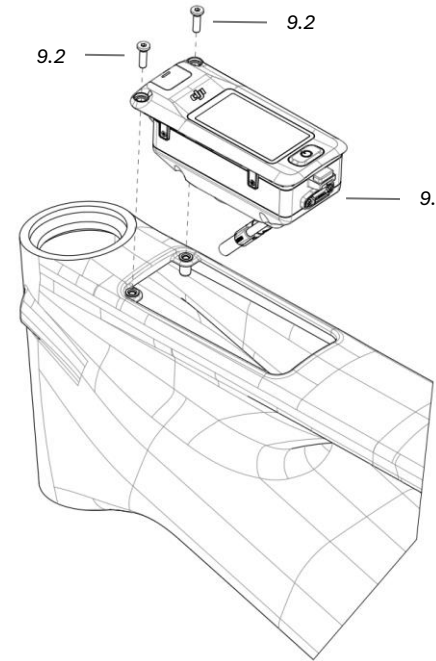



# 18 DISPLAY



## 08 DRIVE UNIT

			QUANT.	TORQUE
	8.1 DJI AVINOX DRIVE UNIT	-	1	-
	8.2 DU - FTAXLE	HU27-001	2	<b>5</b> 20 Nm
	8.3 UNNO DJI 36T CHAINRING	HU27-CHAINRING-002	1	-
	8.4 DJI AVINOX CHAINRING NUT	2024_DJI-CHAINRING-NUT	1	Use DJI Tool YCJGQX00413503 <b>35 Nm</b>

## 09 DISPLAY

			QUANT.	TORQUE
	9.1 DJI AVINOX DISPLAY	-	1	-
	9.2 M3 x 10 H2	YC_ST_LL000500_01_2	2	<b>2</b> 0.8 Nm

# 19 REAR TRIANGLE

## REAR AXLE MITH 2025

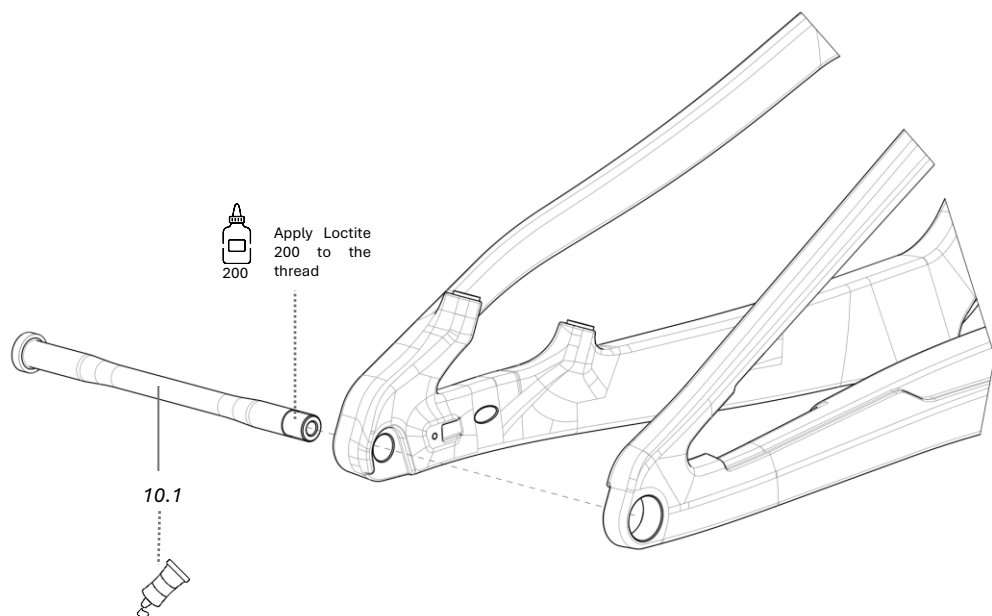

**i** The Unno Mith is designed to be UDH-compatible. Its inclusion will depend on the specific build configuration (T-Type).

## SPEEDSENSOR & POSTMOUNT

**i** All UNNO builds use the Formula disc (200mm) which is designed to work with the DJI System, in case of replacing this disc with another brand of disc, the DJI Speedring must be installed and the nuts DIN125 M3 (10.4) must be removed. For more information please refer to the DJI manual

**i** In the case of replacing the 200mm disc with a 203mm disc, washers DIN125 M6 (10.5) must be installed on the post mount.

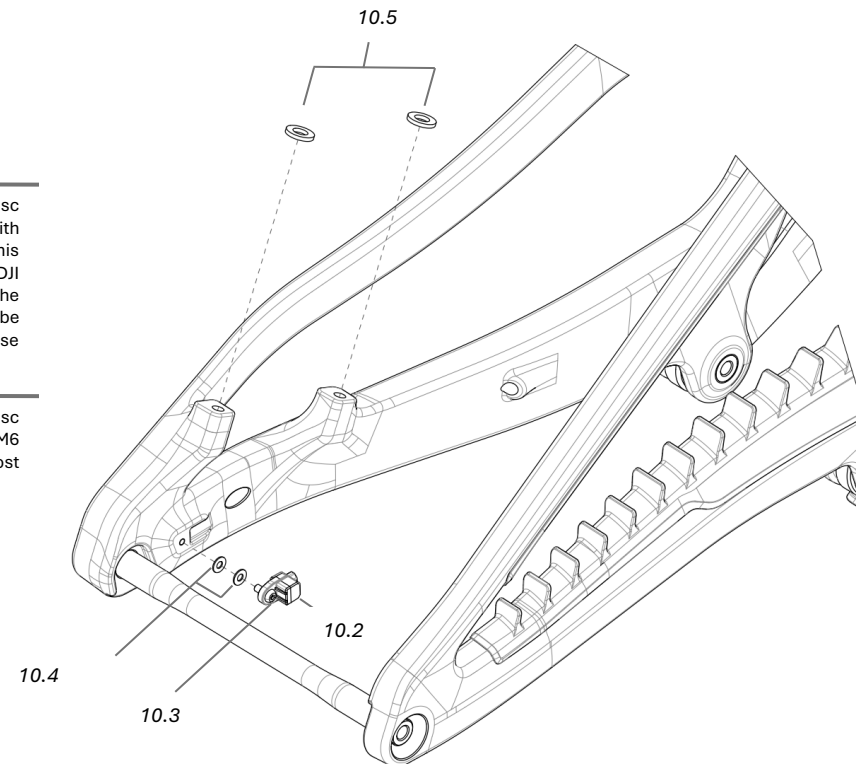



### 10 SPEEDSENSOR

			QUANT.	TORQUE
	<b>10.1 THRU AXLE 148MM OPTION 1</b>	HU12-021	1	<b>6</b> 12 Nm
	<b>10.2 DJI AVINOX SPEEDSENSOR</b>	-	1	-
	<b>10.3 M3 x 8 H2</b>	-	1	<b>2</b> 1 Nm
	<b>10.4 DIN 125 M3</b>	-	2	-
	<b>10.5 DIN 125 M6</b>	-	2	-

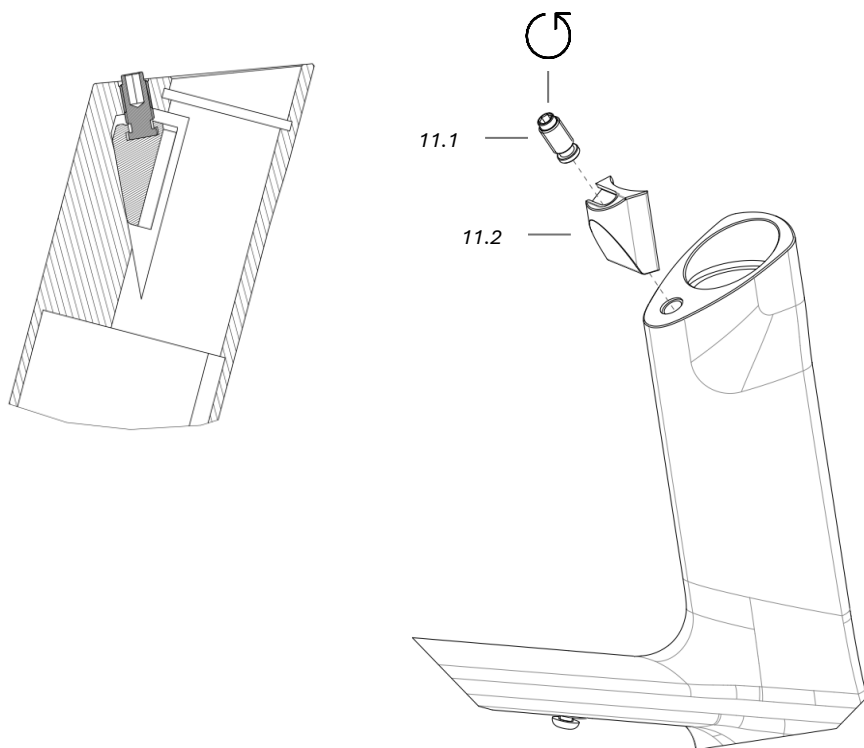
# 20 SEATCLAMP



## 11 SEATCLAMP



		QUANT.	TORQUE
	<b>11.1 SEATCLAMP PRESSING BOLT</b> HU05-077	1	<b>4</b> 7 Nm
	<b>11.2 SEATCLAMP WEDGE</b> HU05-079-01	1	-

# 21 PROTECTORS

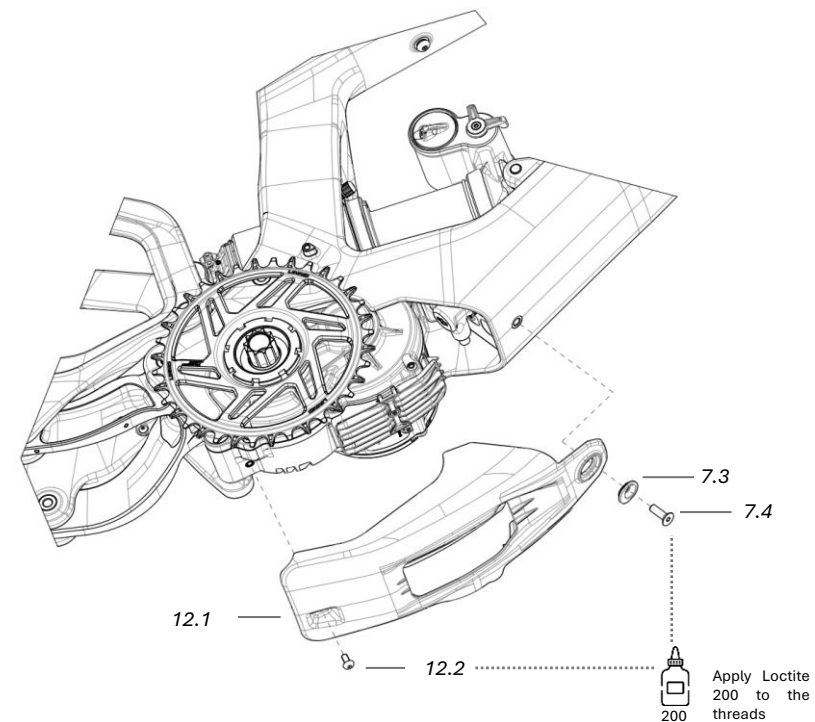
## DRIVE UNIT PROTECTOR



## 12 DRIVE UNIT PROTECTOR

		QUANT.	TORQUE
	<b>12.1 DRIVE UNIT COVER ASSEMBLY</b> HU27-DUCOVER-000	1	-
	<b>12.2 DIN 7380 M4 x 8</b> DIN 7380 M4 x 8	1	<b>2.5</b> 2 Nm

LOWER LINK PROTECTORS

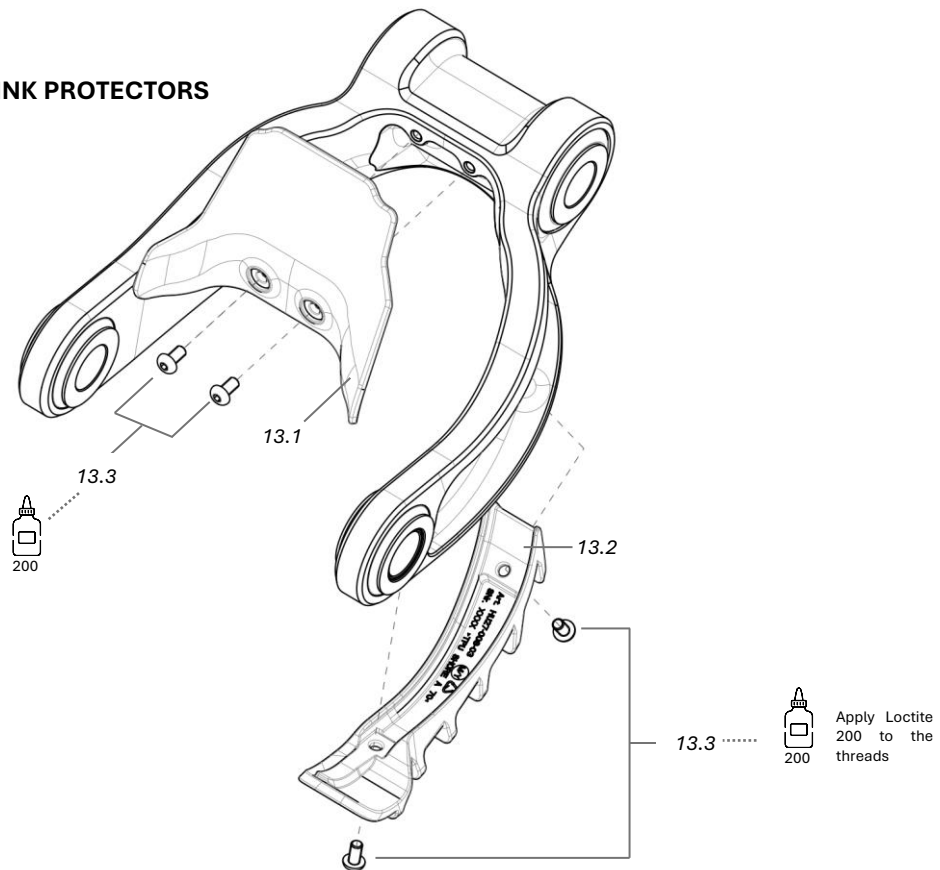

13 LOWER LINK PROTECTORS

			QUANT.	TORQUE
	13.1 MUDGUARD LOWER LINK	HU27-016	1	-
	13.2 LINK PROTECTOR	HU27-008-03	1	-
	13.3 DIN 7380 M3 x 6	DIN 7380 M3 x 6	4	<b>2</b> 0.5 Nm

MUDGUARD

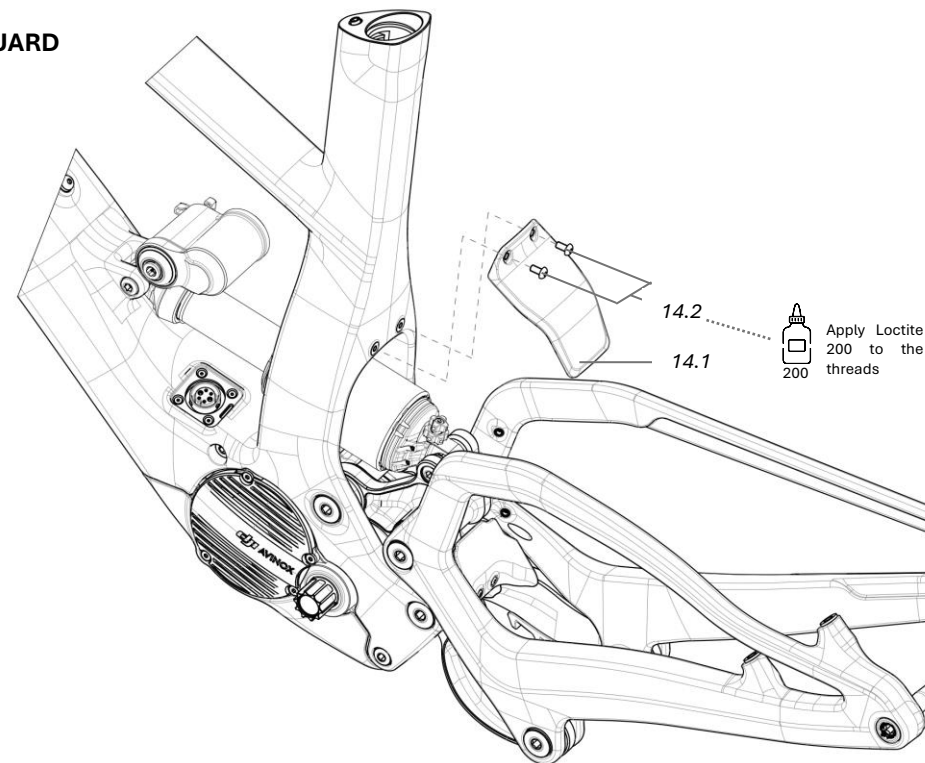

14 MUDGUARD

			QUANT.	TORQUE
	14.1 MUDGUARD	HU27-002-02	1	-
	14.2 DIN 7380 M4 x 8	DIN 7380 M4 x 8	2	<b>2.5</b> 2 Nm

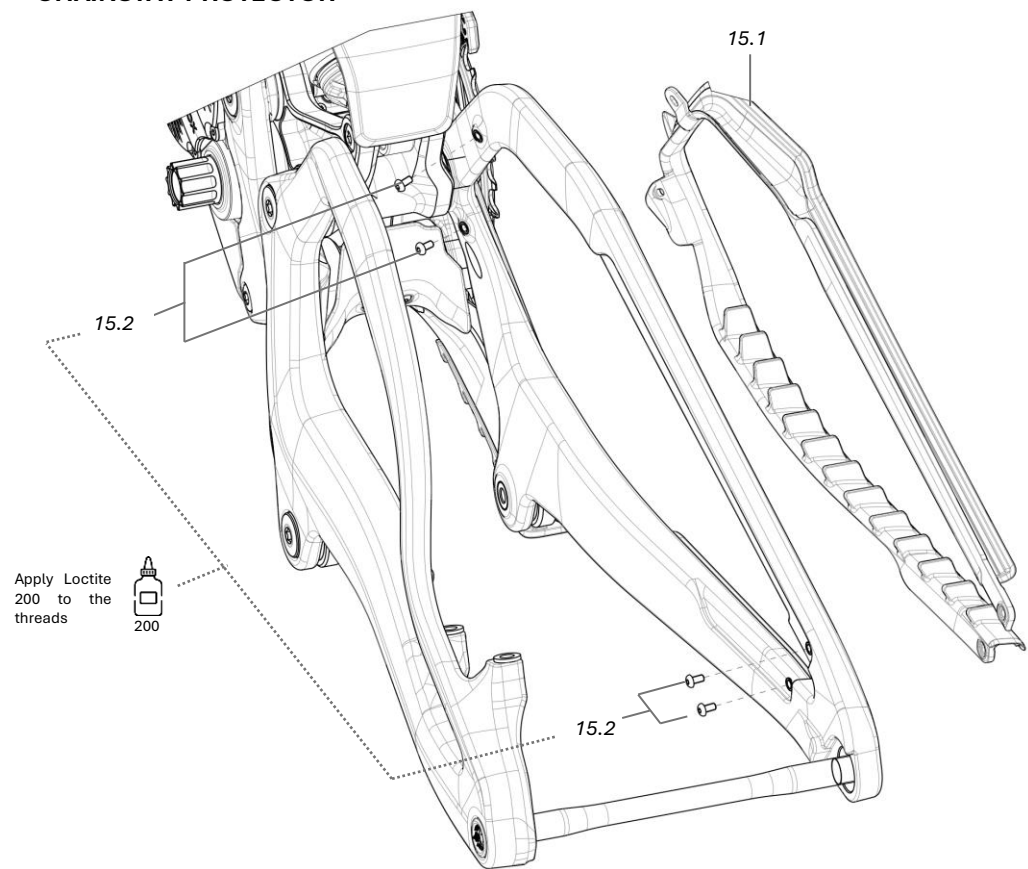

CHAINSTAY PROTECTOR



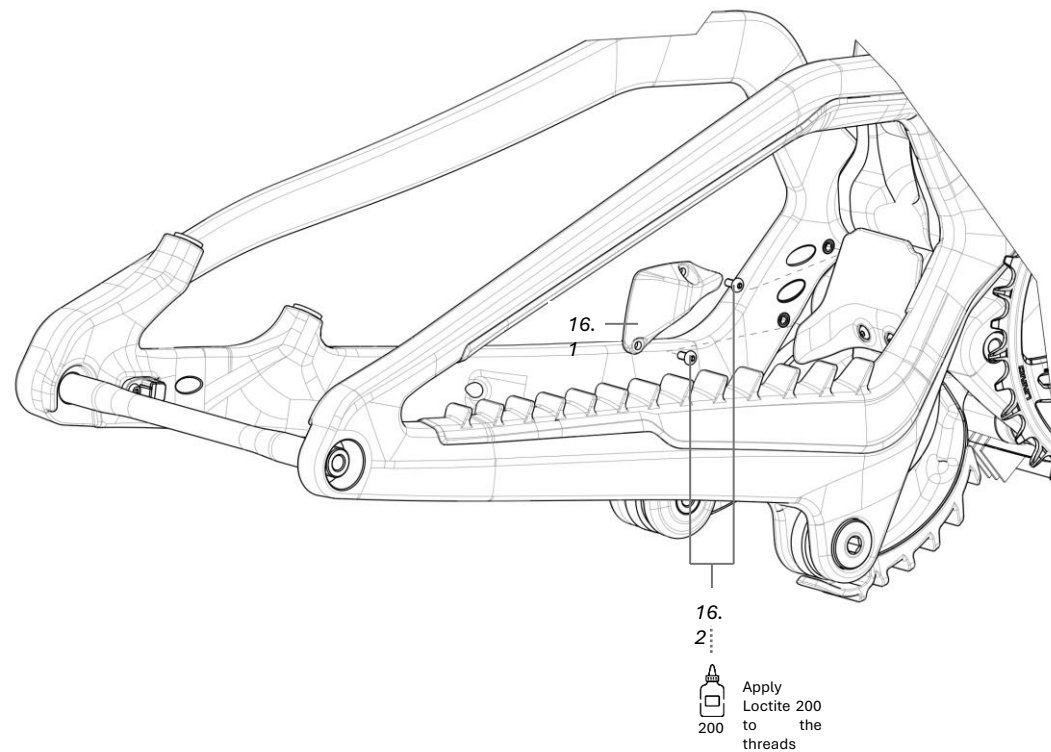

RT CABLE GUIDE



15 CHAINSTAY PROTECTOR

			QUANT.	TORQUE
	15.1 CS PROTECTOR	HU20-013	1	-
	15.2 DIN 7380 M3 x 6	DIN 7380 M3 x 6	4	<b>2</b> 0.5 Nm

16 CABLE GUIDE

			QUANT.	TORQUE
	16.1 RT CABLE GUIDE	HU27-018	1	-
	16.2 DIN 7380 M3 x 6	DIN 7380 M3 x 6	2	<b>2</b> 0.5 Nm

**SEATCLAMP CAP**

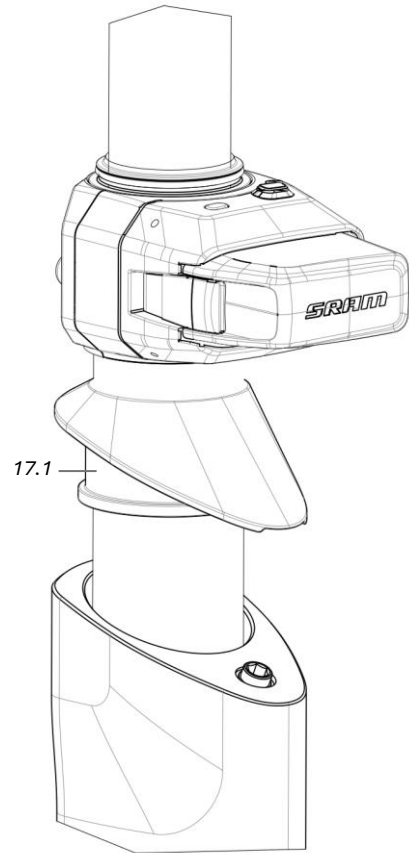

**CHARGER COVER**

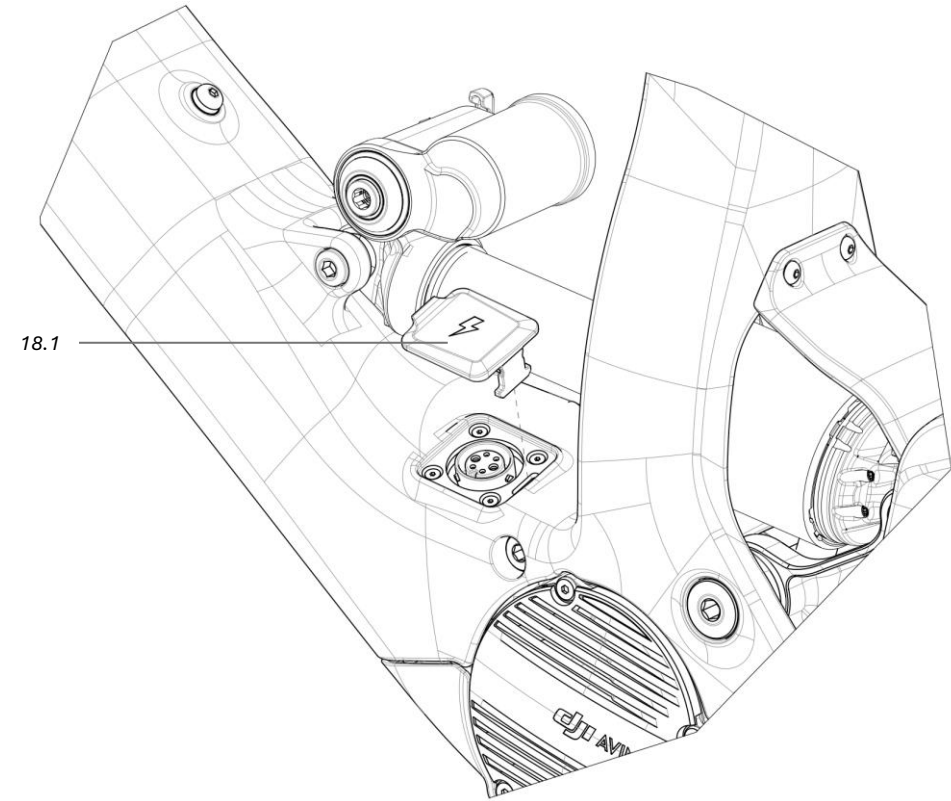

**17 SEATCLAMP CAP**

			QUANT.	TORQUE
	17.1 SEATCLAMP CAP	HU20-022	1	-

**18 CHARGER COVER**

			QUANT.	TORQUE
	18.1 CHARGER COVER	HU27-007-01	1	-

BATTERY CAP

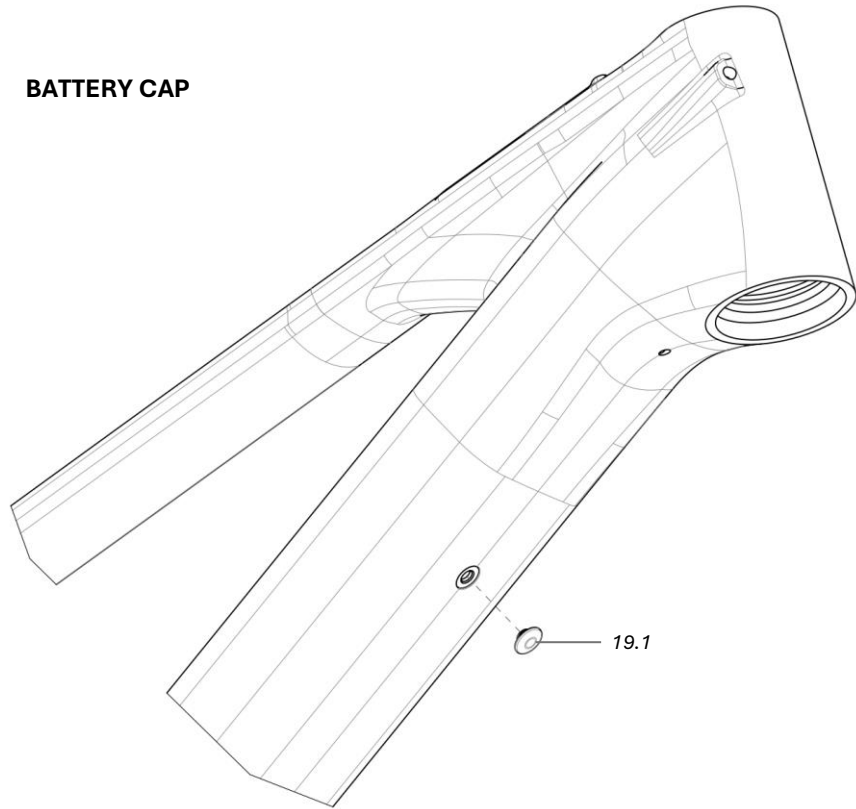



19 BATTERY CAP

			QUANT.	TORQUE
	19.1 BATTERY CAP	HU27-019	1	-

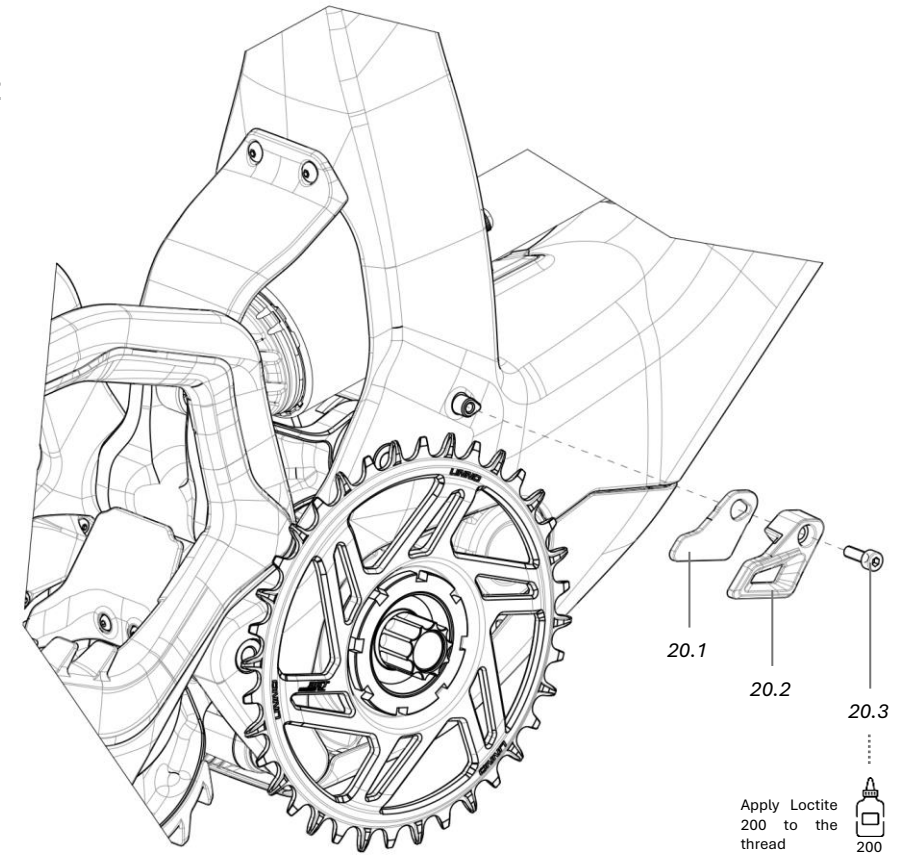
CHAINGUIDE



20 CHAINGUIDE

			QUANT.	TORQUE
	20.1 CHAIN GUIDE	HU27-006	1	-
	20.2 CHAIN GUIDE COINJECTION	HU27-CHAIN-GUIDE-COMOLD	1	-
	20.3 DIN 912 M4 x 12	DIN 912 M4 x 12	1	<b>3</b> 2 Nm

Apply Loctite 200 to the thread



# 22 CABLE ROUTING

CABLE ROUTING IN THE FRAME, REAR BRAKE, SPEEDSENSOR, DROPPER SEATPOST REMOTE

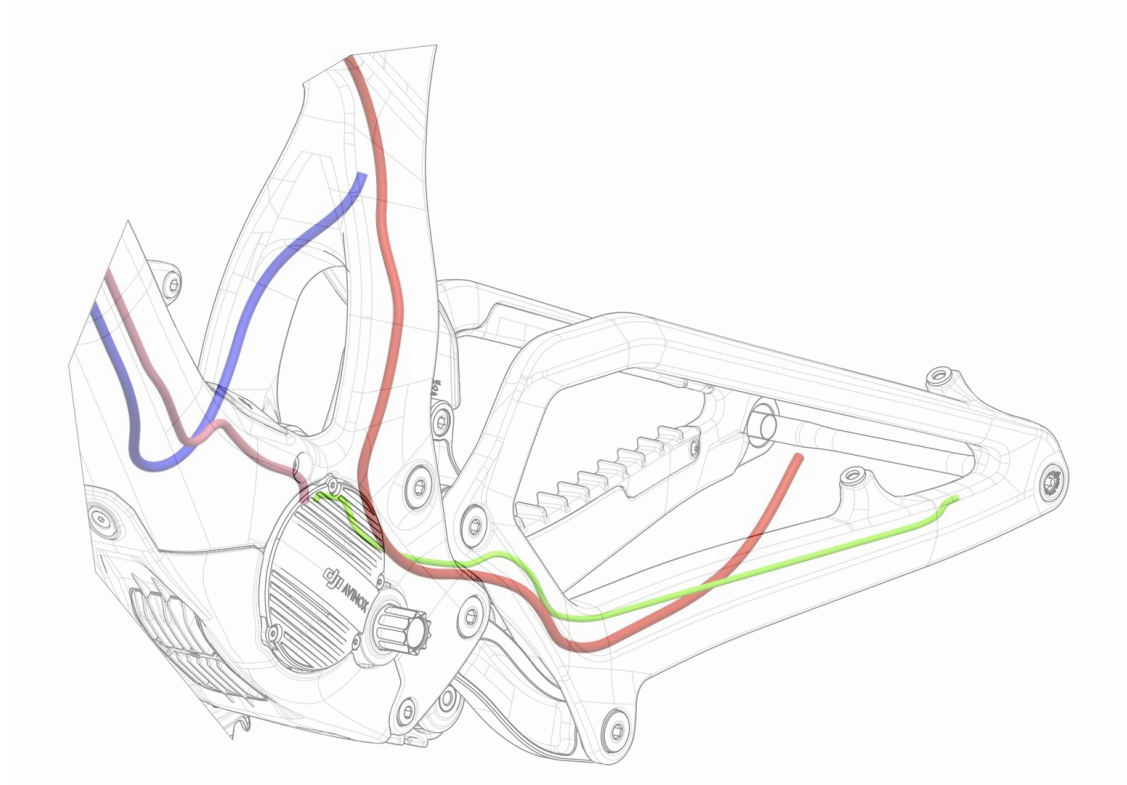

**CABLE LENGTH (MM)**

	<b>S1</b>	<b>S2</b>	<b>S3</b>
<span style="color: red;">■</span> REAR BRAKE CABLE	1479	1527	1555
<span style="color: blue;">■</span> DROPPER SEATPOST REMOTE	1157	1188	1339
FRONT BRAKE	853	866	907
<span style="color: green;">■</span> SPEEDSENSOR	DJI Cable	DJI Cable	DJI Cable
<span style="color: pink;">■</span> DISPLAY	DJI Cable	DJI Cable	DJI Cable

### CABLE ROUTING OF SRAM AXS REAR DERAILLEURS

For Sram AXS rear derailleur setups on Unno bikes, a Sram EP EAC CBL EXTCRD 780MM HIGO MICRO A cable supplies power to the derailleur from the DJI Drive System motor. However, Sram AXS rear derailleurs can function without this cable. In such cases, installing the dedicated Sram AXS battery for the derailleur is required.

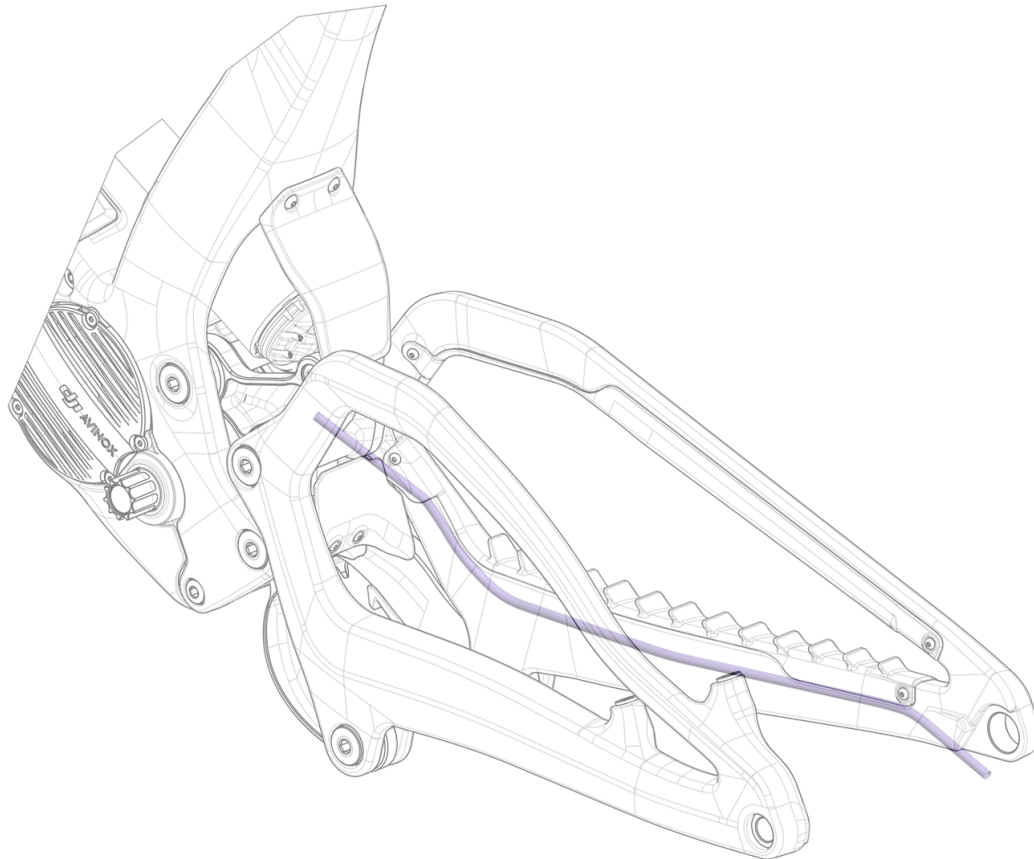

### 21 SRAM AXS REAR DERAILLEUR CABLE

		QUANT.	TORQUE
	<b>21.1 SRAM EP EAC CBL EXTCRD 780MM HIGO MICRO A</b>	00.3018.369.000 1	-

# 23 DJI AVINOX ELECTRICAL SYSTEM

## COMPONENT CONNECTION DIAGRAM

- BATTERY CONNECTOR (Battery Connector – Charger Port)
- POWER CABLE (Drive Unit – Power Connector)
- SPEEDSENSOR CABLE (Speedsensor – Drive Unit)
- HIGH SPEED CABLE (Display – Control Connector)
- EXTENSION CABLE (Display – Extension Connector)

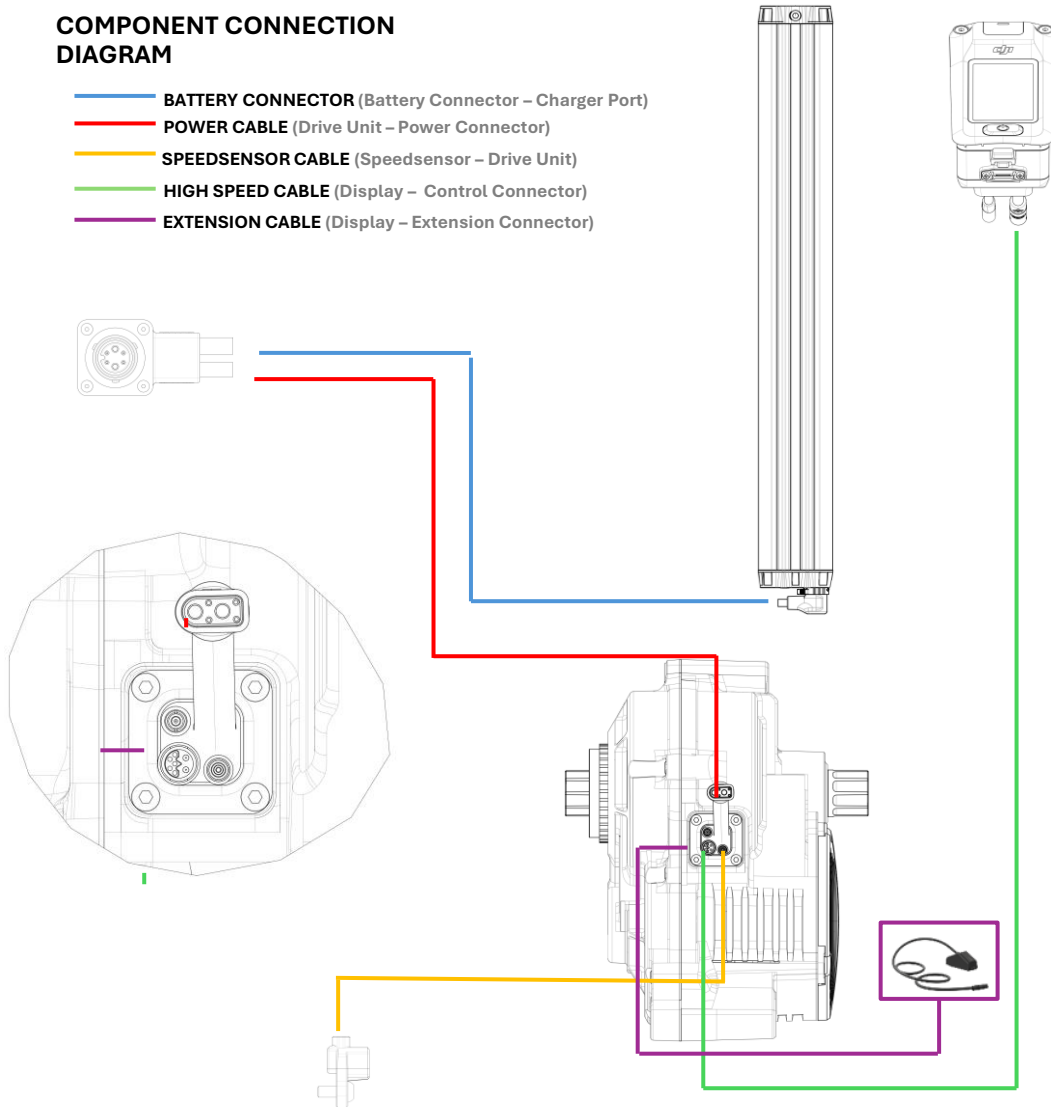

COMPONENT	DJI REFERENCE	
6.2 DJI Y CABLE	YCXCEB90001302	
7.1 BATTERY 800 Wh	-	
8.1 DRIVE UNIT DJI AVINOX M1	ADU01A	
8.4 DJI AVINOX CHAIRRING NUT	YCJGQX00427502	
9.1 DJI DISPLAY	AD01A	
9.2 SCREEN SCREWS	YCWJL0038502	
10.2 DJI SPEEDSENSOR	BCEBAA00010701	
10.3 DJI SPEEDSENSOR SCREW	YCWJL0086802	
21 CONTROLLER LEFT	7MXDMC1003NS03	

COMPONENT	DJI REFERENCE	
22 CONTROLLER RIGHT	7MWDMC5003CJ18	
23 DJI DISPLAY CABLE	YCWCEB90000102	
24 DJI SPEEDRING	YCJGBJ00303502	
25 DJI BATTERY CHARGER	CDX100-528	
26 DJI BATTERY CONNECTOR CHARGER (AUS/NZ)	3VKLM9E00204Q2	
27 DJI BATTERY CONNECTOR CHARGER (US 3VQLM7W00301B9)		
28 SCREWDRIVER NANO SYM CARD	YCJGLD00009303	
29 DJI AVINOX CHAIRRING NUT TOOL	YCJGQX00413503	

## ADVANCED FUNCTIONS

### INSTALLING NANO-SIM CARD

With a nano-SIM card inserted, the bike gains mobile data connectivity, allowing users to link it to the app. This enables remote bike control, real-time status monitoring, and automatic ride data synchronization to the cloud.

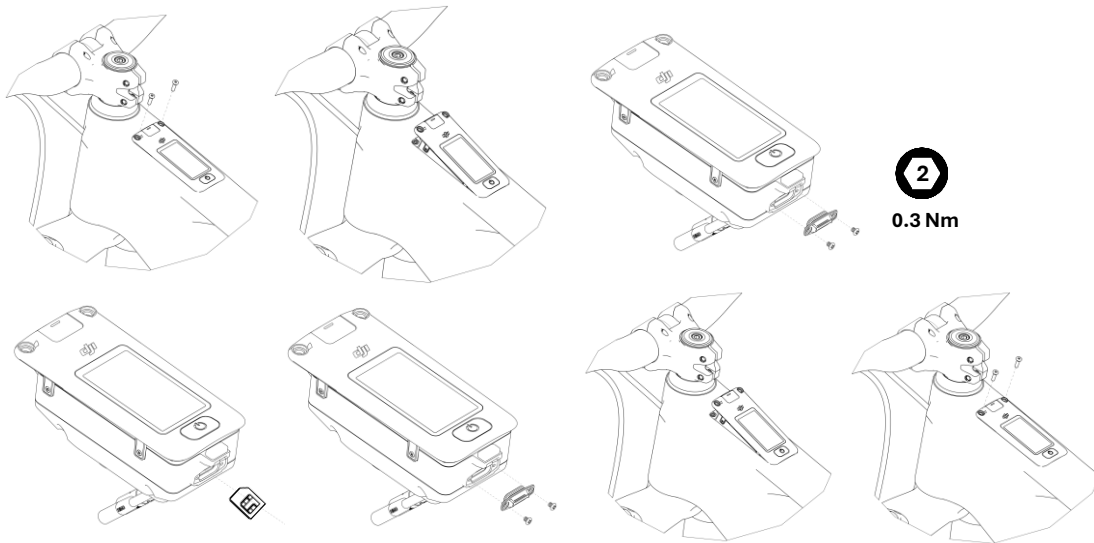

**i** When disassembling it from the frame, use a tool to pry up the control display rather than pulling on the Type-C port cover.

### BIKE CONNECTIVITY

After inserting the nano-SIM card, turn on the control display and open the app. Tap Cloud, then enable Bike Connectivity (SIM). Swipe up on the bike screen to check the signal. If the signal is strong, the app will show a 4G connection once Bluetooth is turned off on the mobile device.

**i** If there is no signal, verify that the nano-SIM card is functioning correctly and that the area has good network coverage.

### RIDE DATA SYNC

Open the app, tap Cloud, and enable Ride Data Sync. Ride data will automatically sync via mobile data, allowing access from other devices by logging into the account.

### BIKE PROTECTION

The drive system includes bike protection features, enabling users to set a digital password and use their phone as a Bluetooth key for automatic unlocking. If the bike is moved unexpectedly, an alarm will sound, and the app will send a notification.

**i** Bike protection functions may be limited in environments below 0°C (32°F) or when the battery level drops below 5%.

**i** Bike protection functions can only be set when the bike and mobile phone are connected via Bluetooth.

Notifications will be sent to the phone only if app notification permissions are enabled.

### PASSWORD AUTHENTICATION

Open the app, go to **Bike Protection > Password Authentication**, and follow the on-screen instructions to set a password. After completing the setup, restart the control display and enter the password on the bike screen to unlock, confirming that password authentication is now active.

### MOBILE KEY UNLOCK

Once password authentication is enabled, users can activate the Mobile Key Unlock function.

1. Open the app, tap **Bike Protection**, and enable **Mobile Key Unlock**. When enabled, the bike will automatically lock when powered off.
2. As you approach the bike with the paired phone, powering on the control display will automatically unlock the bike without needing to enter the password.

 The drive system will automatically power off and lock when the parking time exceeds the set duration for auto power off.

For enhanced security, it is recommended to use a physical lock as well.

#### ACCIDENT DETECTION

Once Password Authentication is enabled, users can activate the Accident Detection function.

1. Open the app, tap **Bike Protection > Theft Detection**
2. After enabling the function if any movement is detected while the bike is locked:
  - The control display will trigger an alarm, and an alert will appear on the screen. Simultaneously
  - The app will send a notification.

 The accident detection notification in the app will only be triggered if the bike and mobile phone remain connected. If they are not connected, only the control display will sound the alarm.

3. Tap **View Bike** Location in the app to see the bike's real-time location and movement trajectory on the map.

- If there is no theft risk, tap **Beep off & Keep Locked** in the prompt to stop the beeping while keeping the bike locked.
- If the movement is authorized, tap **Authorize & Unlock** to unlock the bike, or tap **Cancel** and enter the password on the bike screen to disable the alarm and unlock the bike.



After tapping Authorize & Unlock, the accident detection function will be disabled for one hour. During this time, no alerts will be triggered by any movement.

4. To disable the function temporarily, tap Bike Protection > Suspend Temporarily and choose the duration for suspension.

#### REMOTE BIKE CONTROL

When the bike is connected to the mobile phone via Bluetooth or mobile data, tap Security in the app to expand the map view and check the bike's real-time location and status. If the bike is moved, its movement trajectory will appear on the map. When the drive system is powered on, you can locate the bike by enabling the beep through the app. Additionally, the app allows you to remotely adjust assist modes and other settings.

 When connected to the bike via Bluetooth, users can power on the bike directly through the app.

#### DISABLE BIKE PROTECTION

Users can disable the bike protection functions through the app. To disable Password Authentication, the password must be entered. Once disabled, both Mobile Key Unlock and Theft Detection functions will no longer be active. However, users can disable these two functions individually while keeping Password Authentication enabled.

#### SETTING BIKE SCREEN

Open the app and tap Bike Screen Display to edit, add, or delete the data pages shown on the bike screen.

 Before setting, ensure that the drive system is powered on and connected to the mobile phone.

#### ADDING ACCESSORY

The drive system can connect to various accessories, offering additional ways to record data while riding.

 Simultaneous connection to multiple accessories of the same type is not supported. Be sure to disconnect from the previous device before pairing with a new one.  
To connect a new wireless controller, press and hold both buttons on the controller until the indicator flashes green. Then, follow the on-screen instructions to complete the connection.

1. Press and hold the power button on the control display to turn it on, then power on the accessory.
2. Swipe up on the bike screen to access Settings, tap **Accessories > Add**, and the system will begin searching for nearby devices.
3. Tap the device name displayed on the bike screen to start the pairing process. Follow the on-screen instructions to complete the connection.

The added devices will appear on the **Accessories** page. Tap the device name to view detailed information. To unpair the device, tap **Forget Device**.

#### GEAR SHIFTING SUGGESTIONS

The drive system can provide gear-shifting recommendations while riding. These suggestions help users choose the optimal gear when riding uphill, enhancing pedaling efficiency and overall riding experience.

Power on the control display and swipe up the screen. Then, tap Gear Shifting Suggestions to enable the function. Once enabled, the bike screen will display gear suggestions if a more suitable gear position is recommended for the current riding conditions.

 Adapting to the prompt maximizes assistance efficiency and reduces tension on the chain.

## TROUBLESHOOTING

When the drive system detects an error, a warning will appear on the bike screen. Swipe up to access Settings, then tap System Status to view error details and troubleshooting steps.

---

 If the problem persists, contact DJI Support or an authorized retailer for assistance.

## UPLOAD LOGS

In case of errors or app crashes, open the app, tap Help > Support. Follow prompts in Drive System Errors to export logs to DJI Support for analysis. Tap App Errors to report and get help with encountered issues.

Website  
**DJI DOWNLOADS**



Contact  
**DJI SUPPORT**

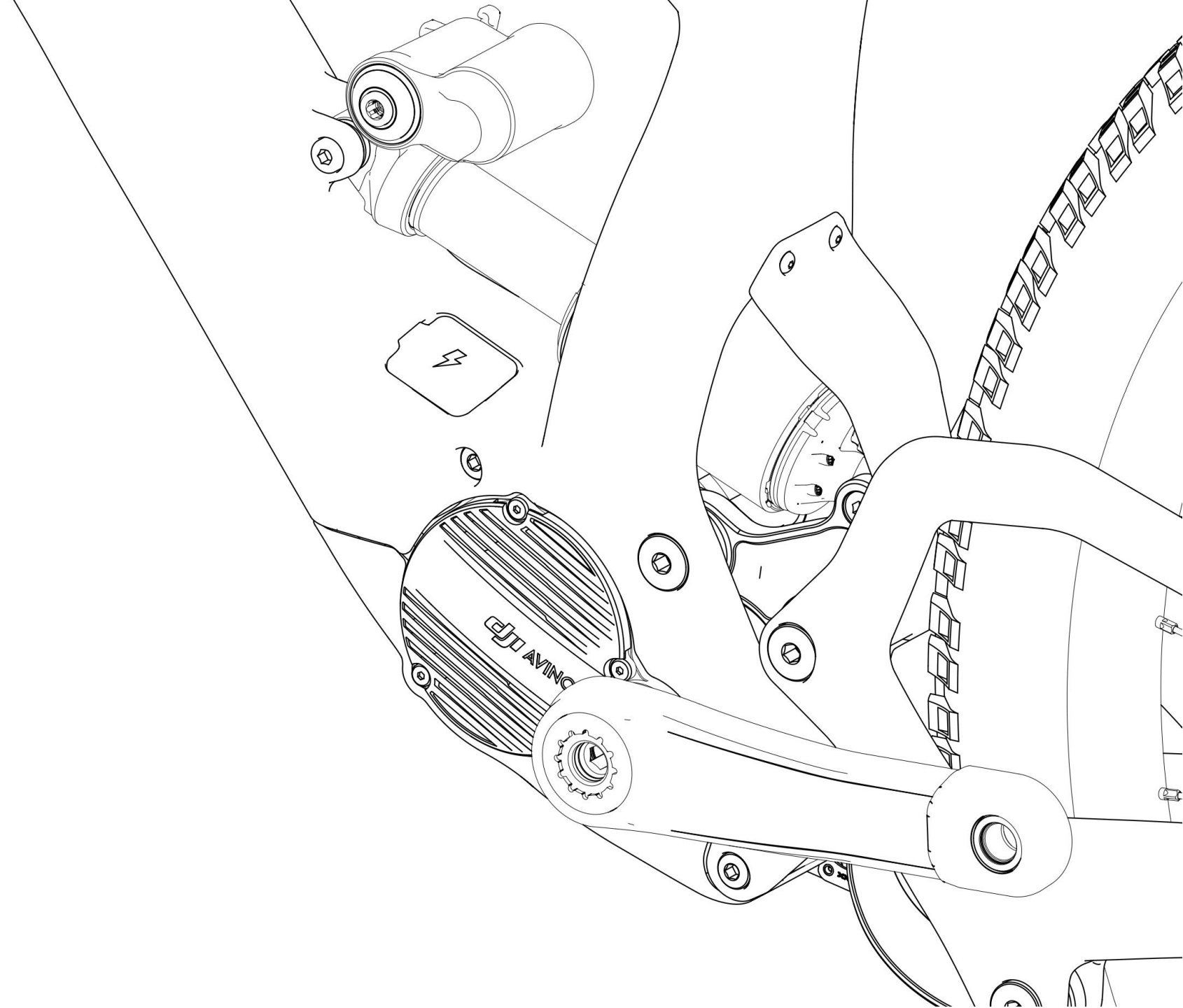

# 24 SUSPENSIONS

## ADJUSTING FORKS

See the full manual for Mith-mounted forks in the manufacturer's documentation.

	Fox main manuals page: <a href="https://tech.ridefox.com/bike/list/owners-manuals">https://tech.ridefox.com/bike/list/owners-manuals</a>
FOX	FOX - 38 FACTORY - 170mm - 2025 <a href="https://tech.ridefox.com/bike/owners-manuals/2979/fork--2025-36mm-or-38mm">https://tech.ridefox.com/bike/owners-manuals/2979/fork--2025-36mm-or-38mm</a>
	FOX - 38 FACTORY - 170mm - 2024 <a href="https://tech.ridefox.com/bike/owners-manuals/2930/fork--2024-36mm-or-38mm">https://tech.ridefox.com/bike/owners-manuals/2930/fork--2024-36mm-or-38mm</a>

## ADJUSTING SHOCKS

	Fox main manuals page: <a href="https://tech.ridefox.com/bike/list/owners-manuals">https://tech.ridefox.com/bike/list/owners-manuals</a>
FOX	FOX - 230x65mm - 2025, FLOAT X2 <a href="https://tech.ridefox.com/bike/owners-manuals/2984/shock--2025-float-x2">https://tech.ridefox.com/bike/owners-manuals/2984/shock--2025-float-x2</a>
	FOX - 230x65mm - 2024, FLOAT X2 <a href="https://tech.ridefox.com/bike/owners-manuals/2926/shock--2024-float-x2">https://tech.ridefox.com/bike/owners-manuals/2926/shock--2024-float-x2</a>
	FOX - 230x65mm - 2025, FLOAT X FACTORY <a href="https://tech.ridefox.com/bike/owners-manuals/2983/shock--2025-float-sl-and-float-x">https://tech.ridefox.com/bike/owners-manuals/2983/shock--2025-float-sl-and-float-x</a>
	FOX - 230x65mm - 2024, FLOAT X FACTORY <a href="https://tech.ridefox.com/bike/owners-manuals/2927/shock--2024-float-sl-and-float-x">https://tech.ridefox.com/bike/owners-manuals/2927/shock--2024-float-sl-and-float-x</a>

## LEVERAGE RATIO

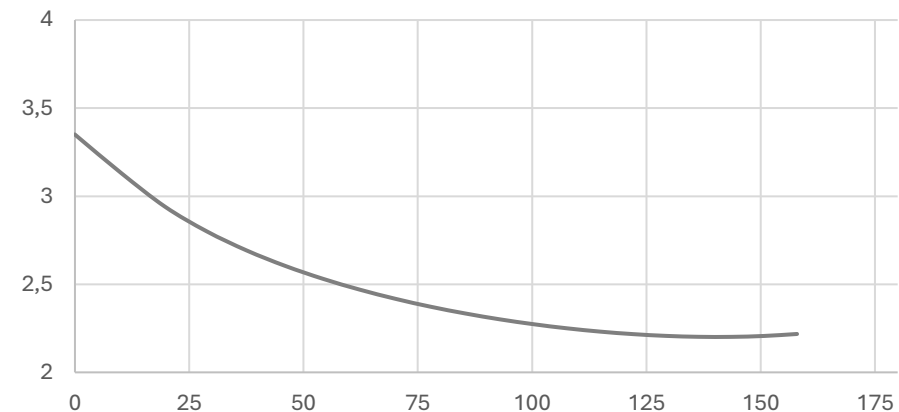

## ANTI-SQUAT

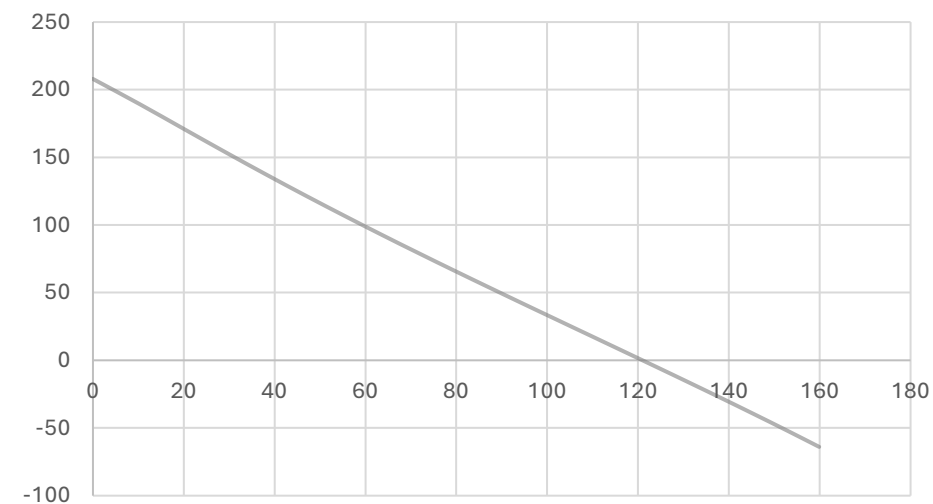

# 24 SUSPENSIONS

## SHOCKS COMPATIBILITY

---

	FOX FLOAT X2 (2026)
	FOX FLOAT (2024)
	FOX FLOAT X (2022)
	ROCKSHOX SIDLUXE ULTIMATE (2024)
<b>AIR</b>	ROCKSHOX DELUXE ULTIMATE (2024)
	ROCKSHOX SIDLUXE ULTIMATE FLIGHT ATTENDANT (2024)
	ROCKSHOX VIVID ULTIMATE SEL (2024)
	OHLINS TTX AIR (2023)
	FORMULA M10I23001 (2023)

---

---

	FOX DHX2 (2026)
	ROCKSHOX SIDLUXE ULTIMATE COIL (2023)
<b>COIL</b>	ROCKSHOX VIVID ULTIMATE COIL (2024)
	OHLINS TTX22M2 (2023)

---

# 25 WARRANTY

Our relentless daily commitment to delivering bicycles of the utmost quality enables us to provide the following warranty coverage and terms:

## LEGAL WARRANTY

The legally mandated **two-year** warranty period comes with specific coverage that includes:

- The affected product will be replaced or refunded, as deemed most suitable in each case, with Unno reserving the right to find the best solution.
- Logistics costs related to the product due to warranty application are covered by Unno. However, if after inspection at our facilities the issue is determined not to fall under the warranty, the return postage costs will be charged.
- Assembly and repair costs to replace affected parts or products are not covered. If you have purchased the bicycle on the second-hand market, Unno does not apply the warranty if you are not warranty registered here <https://www.unno.com/support>
- Wear and tear parts such as bearings (**except for the MITH DJI**), chains, plastic parts, or cassettes are not covered by Unno's warranty.
- In the event of a failure in an external brand component (e.g., NEWMEN or SRAM) due to manufacturing defects, you can contact us for support.

For a complete overview of warranty coverage and legal terms, please visit: <https://www.unno.com/warranty>

## UNNO LIFETIME WARRANTY

In addition to the mandatory legal warranty, Unno also offers an additional limited lifetime warranty covering factory defects on **frames of** all bikes sold from 2022 onwards.

Unno does not cover assembly and repair costs to replace affected parts or products. Unno's lifetime warranty is valid for the owner **only if being warranty registered**. Register for lifetime warranty here <https://www.unno.com/support> Unno's lifetime warranty covers **factory defects** confirmed through either digital or in-person inspection by our team.

## WARRANTY ON ELECTRICAL ASSISTANCE SYSTEM COMPONENTS

### COMPONENTS OF THE DJI SMART SYSTEM

The elements comprising the DJI Avinox System electric setup — such as the motor, screens, speed-detecting magnet, assistance level adjustment button, and dedicated electrical support wiring—benefit from a statutory warranty lasting three years from the item's or bicycle's purchase date. Alternatively, the legally mandated warranty duration in the country of acquisition applies.

Any warranty claims must be handled via DJI through one of the brand's officially recognized distributors.

## BEARING WARRANTY

For the MITH DJI model, Unno offers a lifetime warranty on frame bearings for the owner **only if being warranty registered**. Register for lifetime warranty here <https://www.unno.com/support> Any bearing replacement request must first be assessed by our technical team. Bearings found to be damaged due to improper maintenance — such as use of high-pressure washers or lack of regular upkeep — will not be covered under this warranty.

## WARRANTY CLAIMS PROCESS

All warranty claims can be processed through any authorized Unno dealer or via the **support contact form** you find here <https://www.unno.com/support> The dealer or Unno will conduct the initial diagnosis and gather all necessary documentation to fully assess the claim. The dealer or Unno will update the owner on the status of the process and the decision made by Unno, DJI, or the relevant manufacturer. The handling of warranty claims or repairs for electrical system components will be managed from the dealer you purchased your bike.

In countries where DJI Ebike does not provide after-sales support services, the warranty for electrical system components must be processed through Unno.

Related links

<https://www.unno.com/dealers>  
<https://www.unno.com/support>

# 26 DECLARATION OF CONFORMITY

<b>UNNO</b>		Bolivia 340, Local 46 – 08019 <a href="#">Barcelona</a> ↓ +34 933 078 920   <a href="#">www.unno.com</a>
<b>CE General Certificate of Conformity</b>		
<b>The manufacturer:</b>	UNNO S.L C. Bolivia, 340, Local 46 08019 Barcelona	
<b>Declares that the following products:</b>		
<b>Description:</b>	EPAC	
<b>Brand:</b>	UNNO Mountain Cycles	
<b>Models:</b>	MITH (all sizes)	
<b>Year of manufacture:</b>	2025	
<b>Fulfills the following European Directives:</b>		
	<ul style="list-style-type: none"> <li>• Directive 2006/42/CE</li> <li>• Directive 2004/108/EC</li> <li>• Directive 2011/65/EC</li> </ul>	
<b>The following harmonized standards have been fully applied:</b>		
According to Directive 2006/42/EC		
	<ul style="list-style-type: none"> <li>• EN12100</li> </ul>	
According to Directive 2004/108/EC		
	<ul style="list-style-type: none"> <li>• EN 61000-3-2      EN 61000-3-3      EN61000-6-1</li> <li>• EN 61000-6-3      61000-4-2</li> </ul>	
<b>The following national standard and other specifications (or parts thereof) have been applied:</b>		
	<ul style="list-style-type: none"> <li>• EN 15194</li> <li>• EN 14764</li> </ul>	
<b>Authorized person to elaborate the technical file:</b>		
<b>Name:</b>	UNNO MOUNTAIN CYCLES SL	
<b>Address:</b>	C. Bolivia 340, Local 27 08019 Barcelona, Spain tel. + 34 933 078 920 E-mail: <a href="mailto:info@unno.com">info@unno.com</a> <a href="#">www.unno.com</a>	
18 / 02 / 2025		

# 27 ADDITIONAL INFORMATION

## WEBSITE

<https://www.unno.com/>

## FAQ'S

<https://www.unno.com/faqs>

## UNNO DEALERS

<https://www.unno.com/dealers>

## INSTAGRAM

<https://www.instagram.com/rideunno>

## ABOUT US

<https://www.unno.com/about>

## CONTACT

Acces our data and contact form at:

<https://www.unno.com/contact>

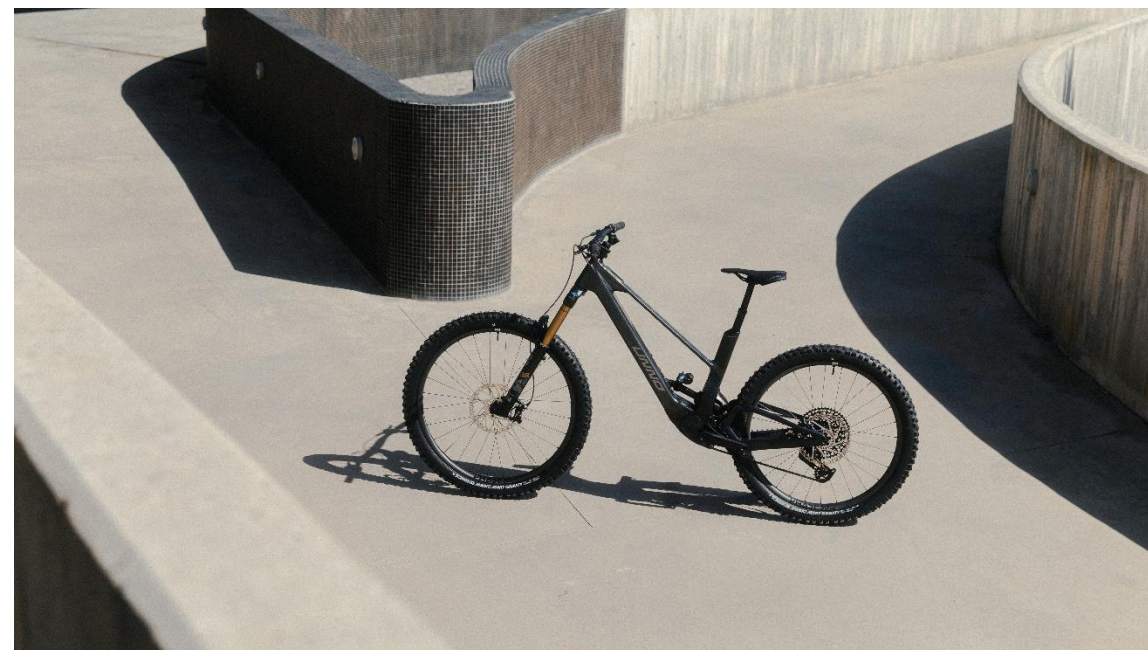

*UNNO*