

# Eagle Transmission

**XX<sup>SL</sup>**   **XX**   **XO**   **GX**  
**90**   **70**   **S-SERIES**



FRAME FIT SPECIFICATIONS

# Table of Contents

## Eagle Transmission

---

<b>Eagle Transmission</b> .....	<b>4</b>
Frame Fit Specification Notes .....	4
<b>Universal Derailleur Hanger &amp; Full Mount Rear Derailleur Specifications</b> .....	<b>5</b>
Hangerless Interface Possible Design Variants .....	6
<b>T-Type Chain</b> .....	<b>12</b>
T-Type Chain Length Chart .....	12
<b>AXS Extension Cord Dimensions</b> .....	<b>13</b>
<b>SRAM AXS Component Power Requirements Gen 2</b> .....	<b>14</b>
<b>Cable Routing Recommendations for Mechanical Derailleurs</b> ...	<b>16</b>

## DUB Cranks

---

<b>T-Type Crankset Clearance</b>	
Drive Side Frame Clearance .....	20
<b>T-Type Crankset Clearance</b>	
Non-Drive Frame Clearance .....	21
<b>Q-Factor</b>	
Measurement Information .....	22
<b>Crank Boot</b>	
Clearance Information .....	23
<b>104 BCD Steel Chainring Spider Requirements</b> .....	<b>24</b>

## Bottom Bracket Shell Specifications

---

<b>BSA 68/73</b>	
Bottom Bracket Shell Specifications .....	26
<b>PressFit 30 73</b>	
MTB Bottom Bracket Frame Shell Specifications .....	27
<b>PressFit</b>	
Bottom Bracket Shell Specification .....	28
<b>BB30</b>	
Bottom Bracket Shell Information .....	29

## DUB Bottom Brackets

---

<b>DUB BSA 68/73</b>	
Bottom Bracket Specification .....	31
<b>DUB PressFit MTB</b>	
Bottom Bracket Specification .....	32
<b>DUB PressFit 30</b>	
Bottom Bracket Specification .....	33
<b>DUB BB30</b>	
Bottom Bracket Specification .....	34

# Eagle Transmission

# Eagle Transmission

## Frame Fit Specification Notes

### General Notes

All dimensions in all referred documents and files are metric unless otherwise noted.

Images in this document are not to scale.

The product's appearance will vary from the models provided.

Information in this document is subject to change.

### T-Type Cassette

For the T-Type Cassette, the specifications are provided in the *UDH and Full Mount Rear Derailleur* zip file at <https://www.universalderaillieurhanger.com>. There is no change to existing freehub designs. If using an XD Driver Body refer to the *XD Driver Body Specifications* at <https://www.xddriverbody.com>.

### Axles

Axles must be a bolt-type thru axles with a 12 x 1.0 mm thread. No option for quick release.

### Chain Stay Growth

For all bikes **without** additional pulleys in the path of the chain:

- Chain Stay Growth is defined by the difference of chain stay length (direct distance BB axis to hub axis) between the fully compressed state and the fully extended state.
- For these bikes, the chain stay growth must be smaller than 27 mm.

For High Pivot Bikes with Idler Pulley (or for any designs that have additional pulleys in the path of the chain):

- The Chain Stay Growth definition **cannot** be applied. For these bikes, the actual Chain Growth needs to be considered.
- **Chain Growth** is defined by the delta of the virtual lengths of a chain routed around the chain ring, the smallest cassette cog, and all frame pulleys, not including the rear derailleur pulleys, between the fully compressed and fully extended state.
- The total chain growth should not exceed 54 mm.
- Orientation of the clearance models provided in the *UDH and Full Mount Rear Derailleur* zip file at <https://www.universalderaillieurhanger.com> need to be adjusted to the specific chain routing.

# Universal Derailleur Hanger & Full Mount Rear Derailleur Specifications

## **Full Mount Rear Derailleur**

For the full mount rear derailleur, the specifications provided at <https://www.universald derailleurhanger.com> must be respected. The **UDH and Full Mount Rear Derailleur** Zip at this site contains the required up-to-date specifications and drawings.

# Hangerless Interface Possible Design Variants

## **The Hangerless Interface**

The "UDH&FULL\_MOUNT\_RD\_FRAME\_SPEC.pdf" defines the dimensional requirements for the Hangerless Interface.

In addition to the design shown in the specification, this document shows other design variants that also fulfill the requirements of the specification.

There must be one element that defines the angular position of the UDH when mounted.

Another element is recommended to stop the rotation when the UDH has fully swung back. This is also needed to take up the removal torque when disassembling the UDH.

Feel free to contact your account manager if you have any questions regarding the Hangerless Interface.

A CAD review of your design by the SRAM drivetrain team is highly recommended.

## Hangerless Interface Design variant 1

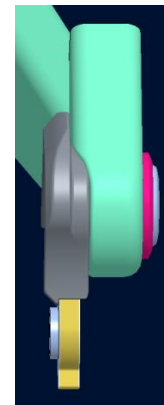
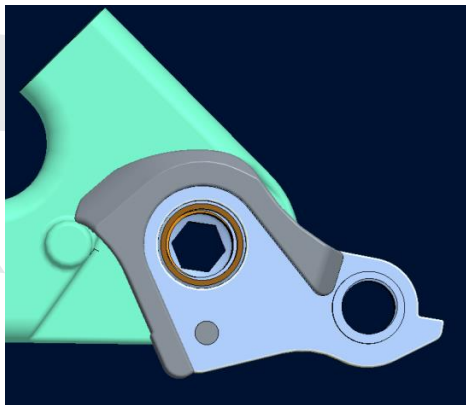
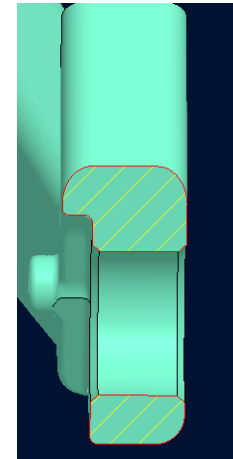
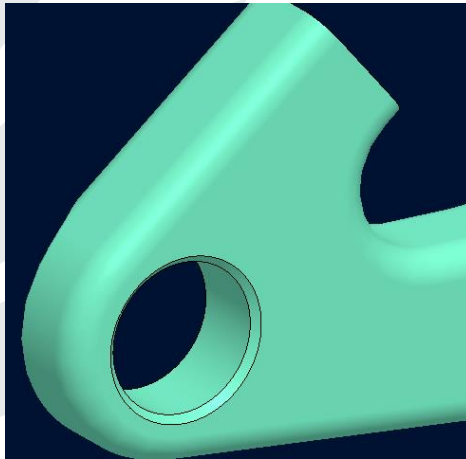
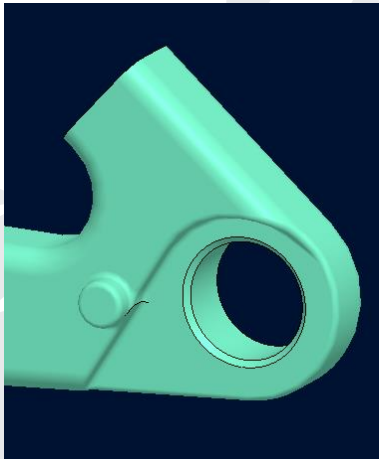

## Hangerless Interface Design variant 2

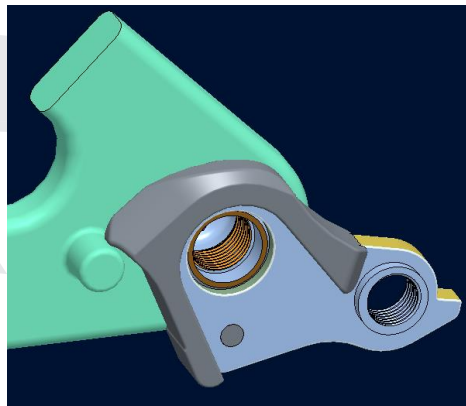
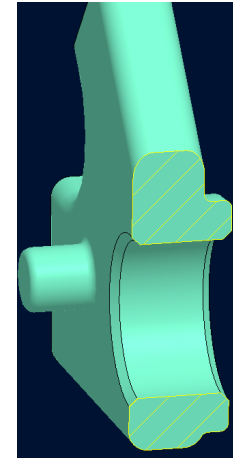
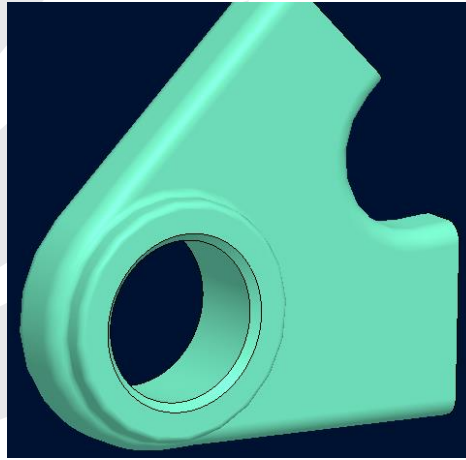
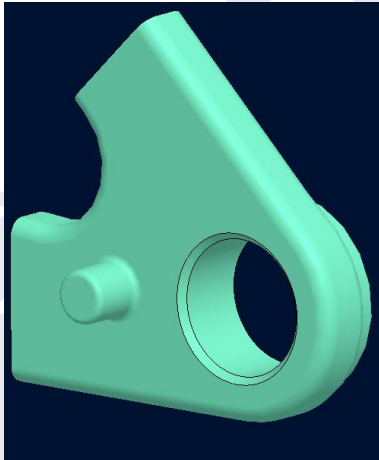

### Hangerless Interface Design variant 3

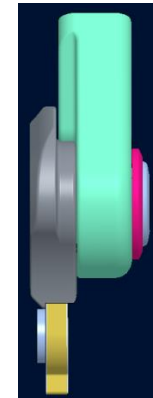
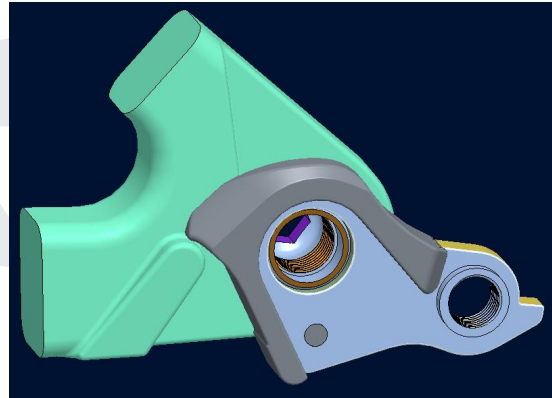
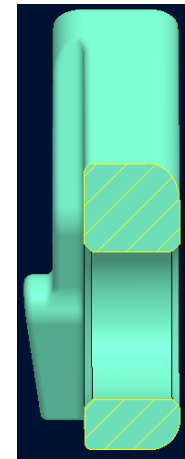
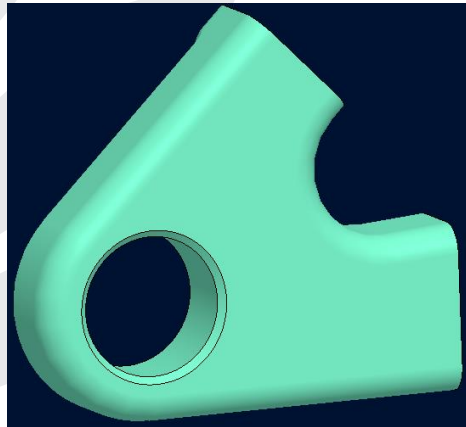
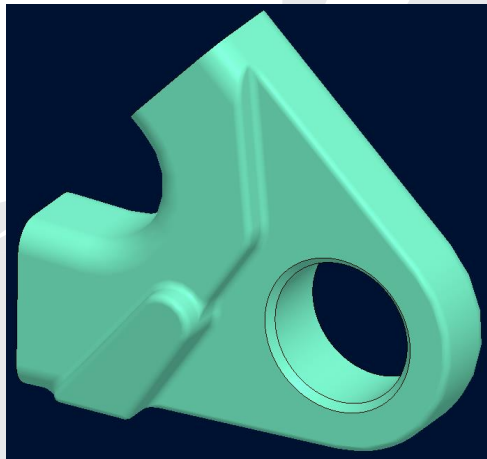

### Hangerless Interface Design variant 4

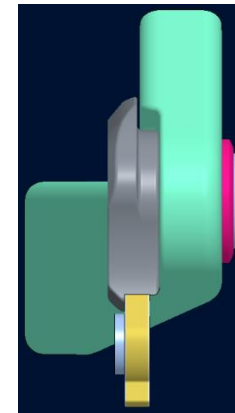
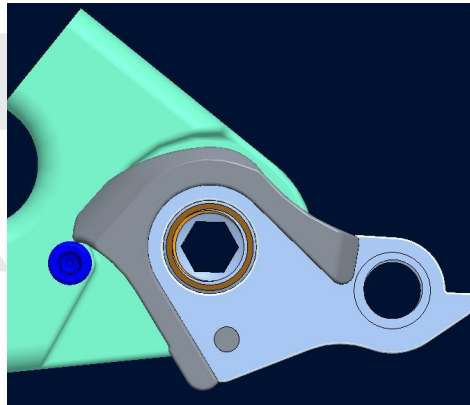
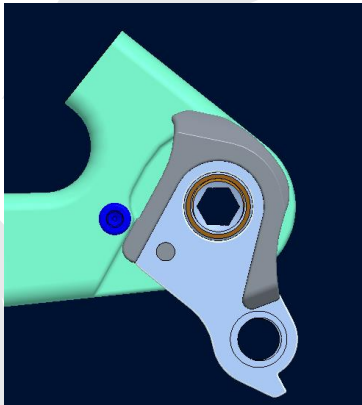
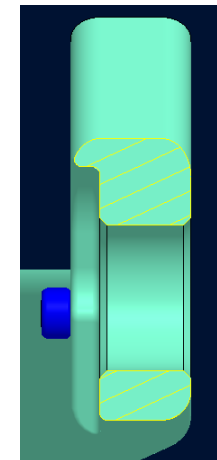
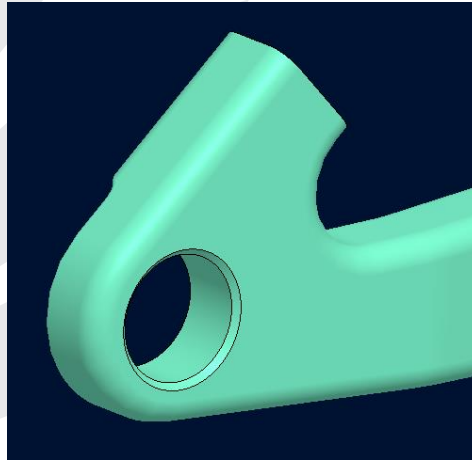
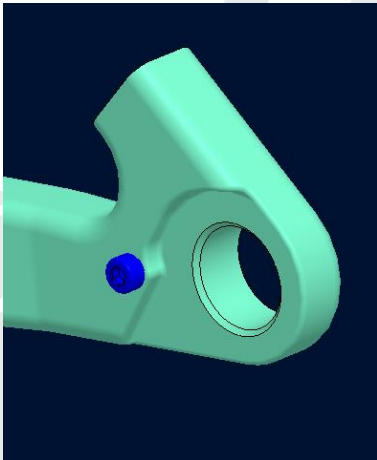

## Hangerless Interface Design variant 5

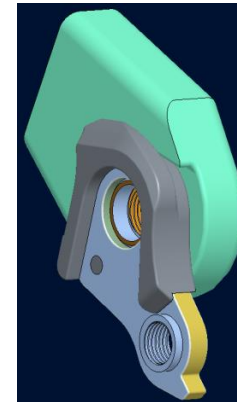
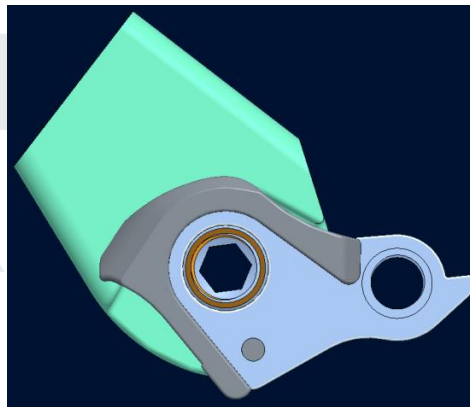
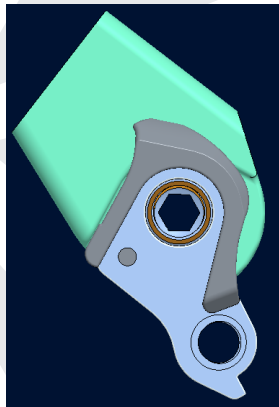
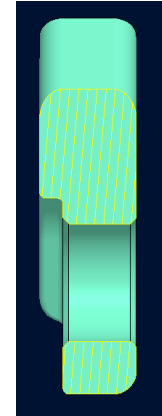
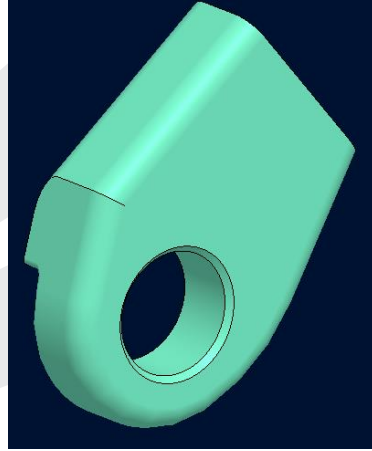
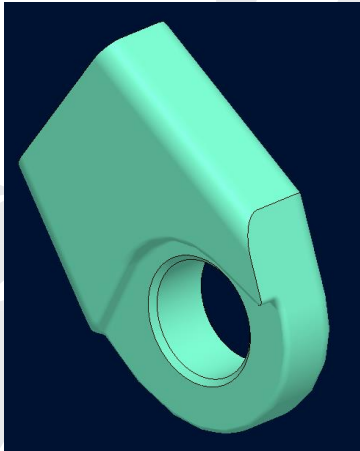

# T-Type Chain

## T-Type Chain Length Chart

Consult the [Full Mount Chain Length Guide](#) or use the **SRAM AXS app** to determine the chain link length calculated for your bicycle.

If your bicycle is not listed in the calculator or app, use this chart to determine the T-Type chain link length for your bicycle chainring and chainstay combination, Setup Key, and Setup Cog for your frame. When the setup determined by SRAM is not known, the system can be set in SAG, setup key A and setup cog 7.

This chart pertains to Eagle Transmission only.

SRAM MTB drivetrains require a minimum chainstay length of 425 mm. Frames that do not meet this requirement must be tested to make sure the drivetrain functions properly.

For Gravel bikes with 142 mm OLD and 47.5 mm chainline, the minimum chainstay length is 415 mm.

### Purple Chart Cells:

Some bicycles may require more than one aftermarket chain to achieve the required length. Use a second compatible PowerLock to connect the chains and place the PowerLocks as far from each other as possible.

### Chainstay Length (mm)

The direct distance from the bottom bracket axis to the hub axis with the frame fully extended at 0% travel.

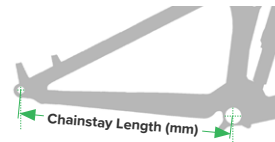

### T-Type Chain Sizing

Count the pins and cut the chain at the correct length. Install the chain with the included T-Type PowerLock.

#### Full Length AM T-Type Chain

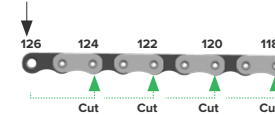

#### T-Type Power Lock



#### Notes:

- Drawings are not to scale.
- Chart does not apply to bikes that have additional idler pulleys in the path of the chain.
- Full length chain size (126) is from AM packaging size.
- T-Type PowerLock installs the same as the Eagle PowerLock. Consult the user manual at [www.sram.com/service](http://www.sram.com/service) for instructions.

### Chainring Size

Chainstay Length (mm)	Chainring Size										
	30	32	34	36	38	40	42	44	46	48	
415 - 421	112		114		116		118		120		122
422 - 427		114		116		118		120		122	
428 - 433	114		116		118		120		122		124
434 - 440		116		118		120		122		124	
441 - 446	116		118		120		122		124		126
447 - 453		118		120		122		124		126	
454 - 459	118		120		122		124		126		128
460 - 465		120		122		124		126		128	
466 - 472	120		122		124		126		128		130
473 - 478		122		124		126		128		130	
479 - 484	122		124		126		128		130		132
485 - 491		124		126		128		130		132	
492 - 497	124		126		128		130		132		134
498 - 503		126		128		130		132		134	
504 - 505	126		128		130		132		134		136

# AXS Extension Cord Dimensions

AXS Extension Cord			
MAX Length Connector D	MAX Diameter Connector E	MIN Bending Radius F	MAX Cable Diameter G
19	Ø 5.8	8.4	Ø 4

For compatibility with the AXS Extension Cord, a cylinder diameter (diameter and length), must pass through the designated internal cable routing path of the frame.

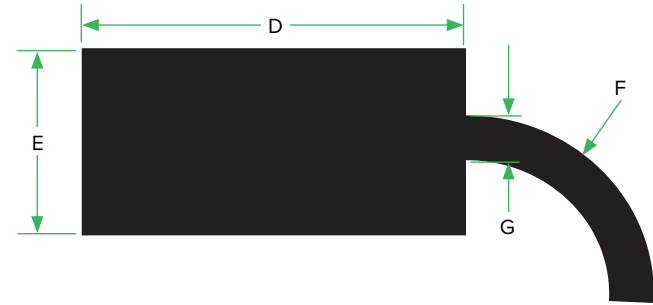

# SRAM AXS Component Power Requirements Gen 2

EP-EAC-ECD-A1 / EP-ETP-ECD-A1

## Voltage

The SRAM extension cord is designed to work with E-Bike power supplies and accessory power ports with a nominal output voltage of 8-48V.

## Current

Input supply to adapter shall provide current to SRAM AXS components without penalty, current limiting, or disabling of accessory power to allow the SRAM AXS components to operate within the following specification.

Input current specification of SRAM AXS components:

### 10.5-13.5V Systems

- Continuous current:  $I_c \leq 1A$
- Peak current:  $I_p \leq 3.7A$  for  $t(on) \leq 0.5s$ , average  $I_a \leq 1A$

### 36V Systems

- Continuous current:  $I_c \leq 0.4A$
- Peak current:  $I_p \leq 1.3A$  for  $t(on) \leq 0.5s$ , average  $I_a \leq 0.4A$

### 48V Systems

- Continuous current:  $I_c \leq 0.3A$
- Peak current:  $I_p \leq 1.1A$  for  $t(on) \leq 0.5s$ , average  $I_a \leq 0.3A$

## Power Availability

As system supplier, the bike OEM is ultimately responsible for any handling of shutdown conditions due to low state of charge of the E-Bike main battery.









SRAM recommends the following guidelines as best practice:

- Power to SRAM AXS components shall be continuously available as long as the E-Bike system is powered on.
- User shall not be able to disable the supply of SRAM AXS components via bike UI.
- Full power to SRAM AXS components shall be available thru end of battery capacity, including period of safety/lights-only operation. Even if E-Bike assist is turned off due to low system battery SOC, SRAM AXS components shall be supplied in order to remain usable and operational at any time that bicycle is rideable.
- In case of multiple SRAM AXS components, the priority of availability is solely in the responsibility of the bike OEM.

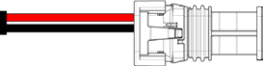
## Mechanical Requirements

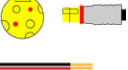
For all variants, dimensions and specifications must be considered to pass through the designated internal cable routing path of the frame.

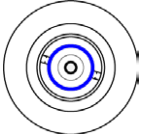
SRAM will supply the AXS extension cord variants with the following mechanical specification:

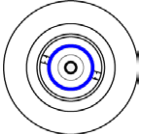
Model Code	Part Number	Intended System Use*	Minimum Cable Length (mm)	Cable Diameter (mm)	Minimum Cable Bending Radius (mm)	Connector Dimensions (mm)	Connector Length (mm)	Connector Illustration	Pin Assignment
EP-EAC-ECD-A1	00.3018.316.000	BOSCH <sup>1</sup> GEN4 BES2	880	4.0	20.0	Refer to <a href="#">TYCO's User Manual</a> (Cross section: 11.3 x 7.3 mm)	Refer to <a href="#">TYCO's User Manual</a> (Length: 22.2 mm)		
	00.3018.316.010	BOSCH <sup>1</sup> GEN4 BES2 (KIT <sup>2</sup> )	880	4.0	20.0	No connector attached; connector provided separately.	No connector attached; connector provided separately.		
	00.3018.317.000	BOSCH <sup>1</sup> GEN5 BES3	880	3.0	9.0	Ø5.7	17.5		
	00.3018.369.000	HIGO MICRO A	780	2.8	8.4	Ø4.8	18.9		
EP-ETP-ECD-A1	00.3018.318.000	SRAM Eagle Powertrain	780	2.8	8.4	Ø4.8	18.9		
	00.3018.318.001	SRAM Eagle Powertrain	955	2.8	8.4	Ø4.8	18.9		

\*Consult your SRAM Account Manager for compatibility with systems not listed in the table.

<sup>1</sup>To use the AXS Extension cord with a BOSCH motor unit, BOSCH HPP needs to get activated by the BOSCH motor firmware. Consult BOSCH OE documents for further instructions. Do not shorten the cable. To hide extra cable length, loop the cable inside BOSCH motor compartment or under cover as described in BOSCH OE documentation, [BDU4xx\\_Cable\\_Routing\\_NewCX\\_20180314.pdf](#).

<sup>2</sup>Two versions of the cord are available for the BOSCH G4 BES2 Drive Unit:

00.3018.316.000 - Assembled plug with OEM specification.

00.3018.316.010 - Open end with loose plug for OEM specification. Please consult page 3 and 4 in [TYCO's User Manual](#) for assembly instructions. If using the open-end version, it is the responsibility of the bike OEM and drive unit manufacturer to assemble the loose connector provided in the package.

# Cable Routing Recommendations for Mechanical Derailleurs

- Use dedicated derailleur cables and housings with compressionless housing, low friction liner, aluminum ferrules, without sealing and 1.1 mm polished cable.
- Ferrule diameter 5.7+0.1 mm.
- Continuous housing only.
- Maximum total bend angle of 500°.
- Minimum bend radius of 50 mm.
- Avoid: S-Bends with small radii and pinch spots (high housing clamping force).
- Minimize cable bending due to suspension and handlebar motion.

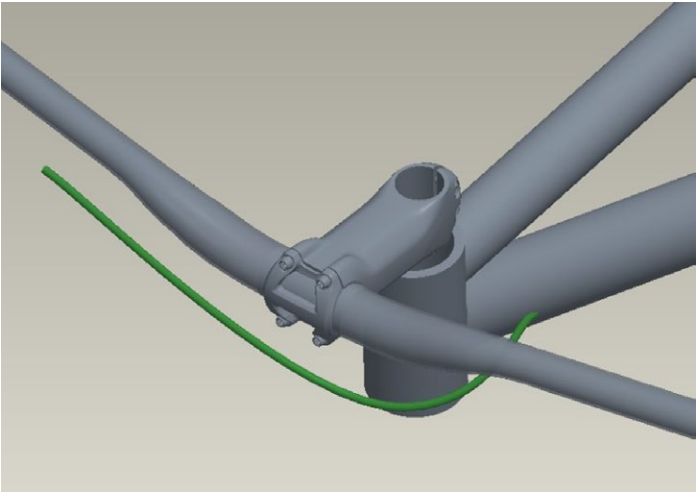
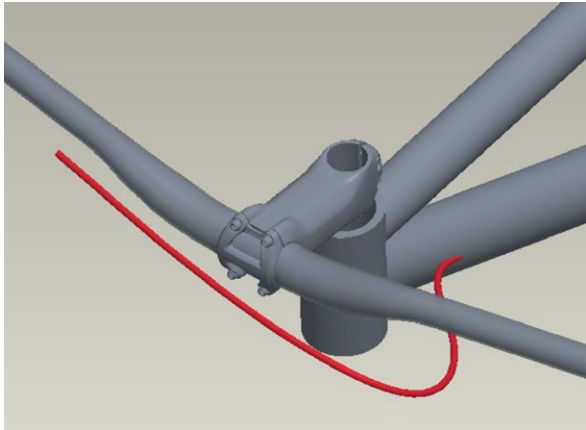
EXAMPLES OF IDEAL CABLE ROUTING	EXAMPLES OF CABLE ROUTING TO AVOID
<ul style="list-style-type: none"><li>• Small bow with relatively flat entrance into downtube.</li><li>• Total bend angle shown <math>\sim 120^\circ</math>.</li></ul> 	<ul style="list-style-type: none"><li>• Large bends with steep angles into downtube.</li><li>• Total bend angle shown <math>\sim 230^\circ</math>.</li><li>• Note: Large bends alone are not all bad, but they can result in more bend angle than smaller bends.</li></ul> 

**EXAMPLES OF IDEAL CABLE ROUTING**

- Straighter routing internal or external.

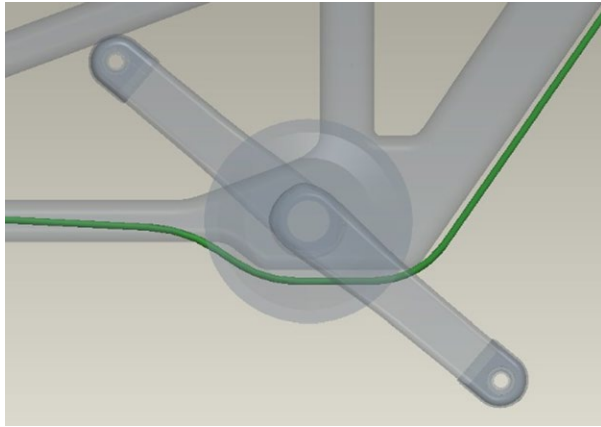

**EXAMPLES OF CABLE ROUTING TO AVOID**

- Many bends with small radii.
- Total bend angle between section 1 and 2,  $\sim 180^\circ$ .

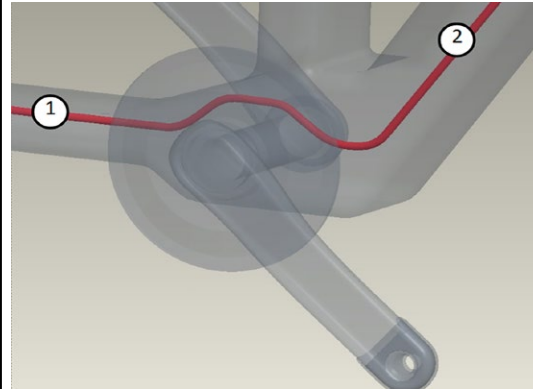

- Straighter routing internal or external.

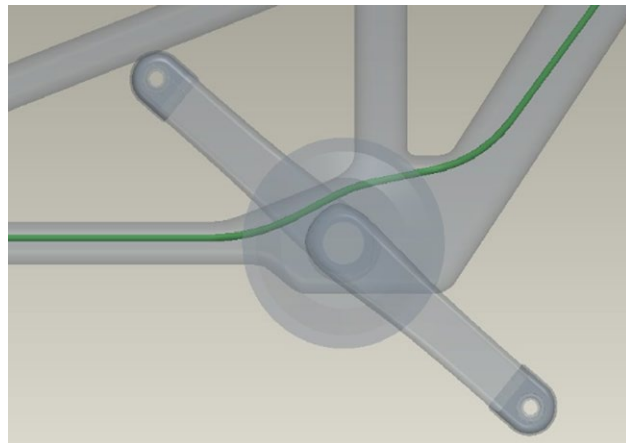

- Many bends with small radii.
- S-bends and sharp angles.
- Total bend angle between section 1 and 2,  $\sim 210^\circ$ .

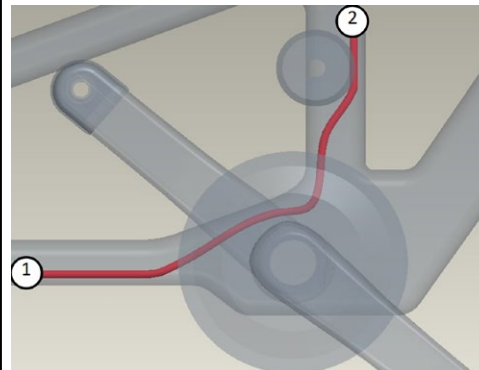

### EXAMPLES OF IDEAL CABLE ROUTING

- Straighter routing through headset with shallow bends.
- Routing from shifter into downtube: total bend angle  $\sim 150^\circ$ .
- Note: Design of the stem, head set cups and spacers should avoid any risk of clamping the housing. Too tight bows entering the head set from the shifter should be avoided.

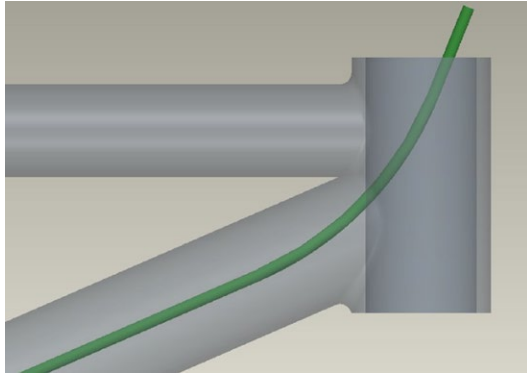

### EXAMPLES OF CABLE ROUTING TO AVOID

- Big total bend angle and small radii between section 1 and 2.
- Total bend angle and small radii between section 1 and 2  $\sim 260^\circ$ .

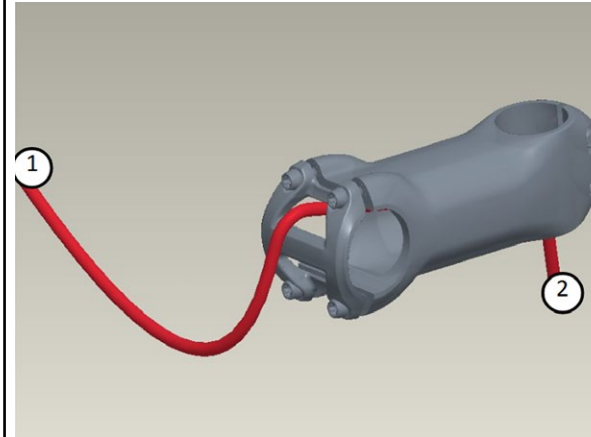

- Cable Exit on top (Green).
- Creates shallower angle and larger bend radius.

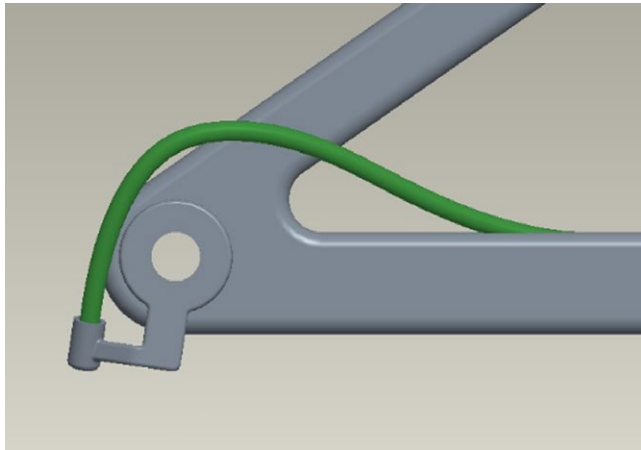

- Cable exit on bottom (Red).
- S-bends creates multiple sharp bend angles with a small section.

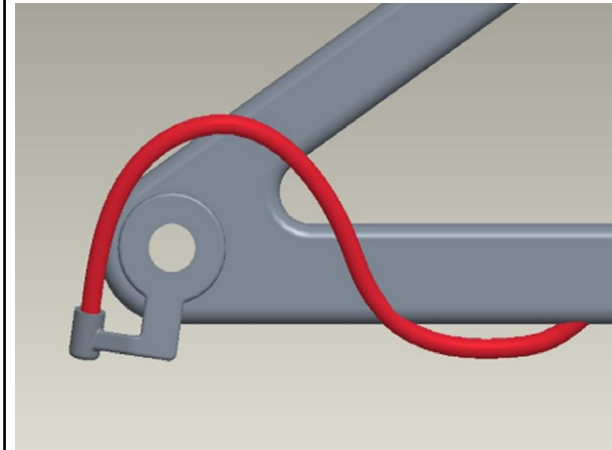

# DUB Cranks

## Eagle Transmission

The Eagle Transmission is optimized for chainlines between 52 mm and 55 mm. A 52 mm chainline crank must be configured using a 168 mm Q-factor crank with a 3 mm offset T-Type Chainring.

Crankset versions may include:

- XX SL crankset with a 168 mm or 174 mm Q-factor.
- Cranksets with an integrated chain guard with 174 mm Q-factor
- Powermeter cranksets with a 168 mm or 174 mm Q-factor.

For third party spiders and E-MTB use, chainlines between 52 mm and 55 mm are compatible.

The 52 mm chainline must be used with 142 mm OLD MTB frames. This must be configured using a 168 mm Q-Factor crank with a 3 mm offset T-Type Chainring.

For frames with a 157 mm OLD, a 55 mm chainline crankset can be used.

For 142 mm OLD ROAD frames, a 52 mm chainline is optimal, but a 47.5 mm chainline DUB ROAD crank can be used.

Existing non-T-Type chainrings are **not** compatible with the Eagle Transmission.

All crankset versions are compatible with 148 mm OLD (Boost™) hubs.

# T-Type Crankset Clearance

## Drive Side Frame Clearance

Crankset	CL	Q-Factor	L2	L3	W1	W2	W5*	Spindle Type	Chainring Offset
XX SL*	55	168	-	②	52.5	53	70.5	DUB MTB	0 mm
XX SL XX	55	174	-	②	53	53	73.5	DUB MTB Wide	3 mm
X0 GX X0 PM	55	174	60.5 ①	②	52.5 ①	53	73.5	DUB MTB Wide	3 mm
XX SL PM*	55	168	49	②	48	53	70.5	DUB MTB	0 mm
XX SL PM XX PM	55	174	49	②	51	53	73.5	DUB MTB Wide	3 mm

Bottom Bracket Type(s): DUB BSA 73 : DUB BB30 : DUB PF30 : DUB PF 89.5/92

\*Dimensions will vary for cranks equipped with crank boots. Consult the section titled "Crank Boot."

①Applies only on Chainrings with Guards. Measured on 36T Chainring (maximum size offered with guards).

②Varies with ring size. See additional table.

Chainring	L3
30T	64.3
32T	68.3
34T	72.3
36T	76.4
38T	80.4

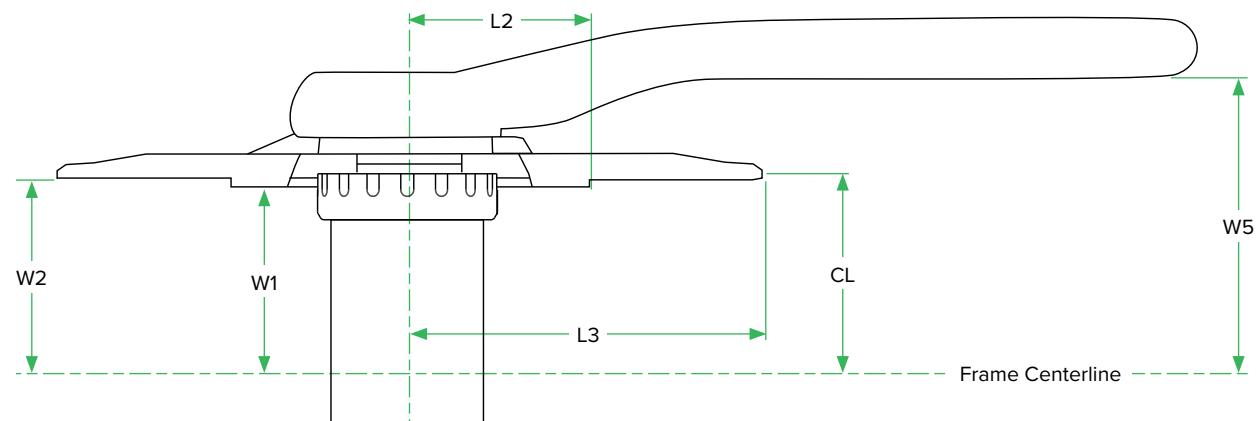

# T-Type Crankset Clearance

## Non-Drive Frame Clearance

Crankset	Q-Factor	CL	W1	W2	W3	W4	W5	W6	W7*
XX SL	168	55	56.3	58.4	68	70.3	70.6	70.7	70.8
XX SL XX X0 GX	174	55	61	62.2	69.7	72	73.1	73.5	73.6

Bottom Bracket Type(s): DUB BSA 73 : DUB BB30 : DUB PF30 : DUB PF 89.5/92

\*\*Dimensions will vary for cranks equipped with crank boots. Consult the section titled "Crank Boot."

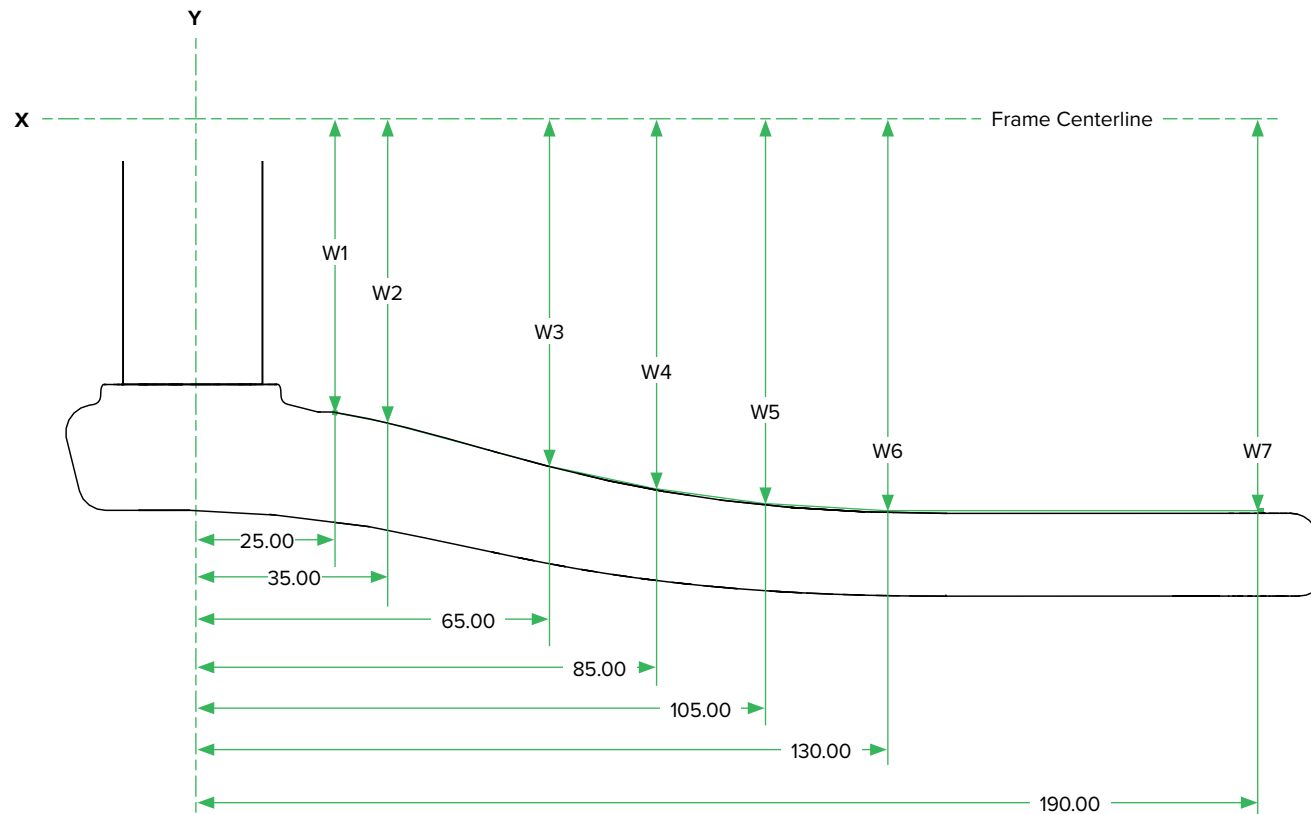

# Q-Factor

## Measurement Information

Q-Factor is the distance between the two pedal spot faces.

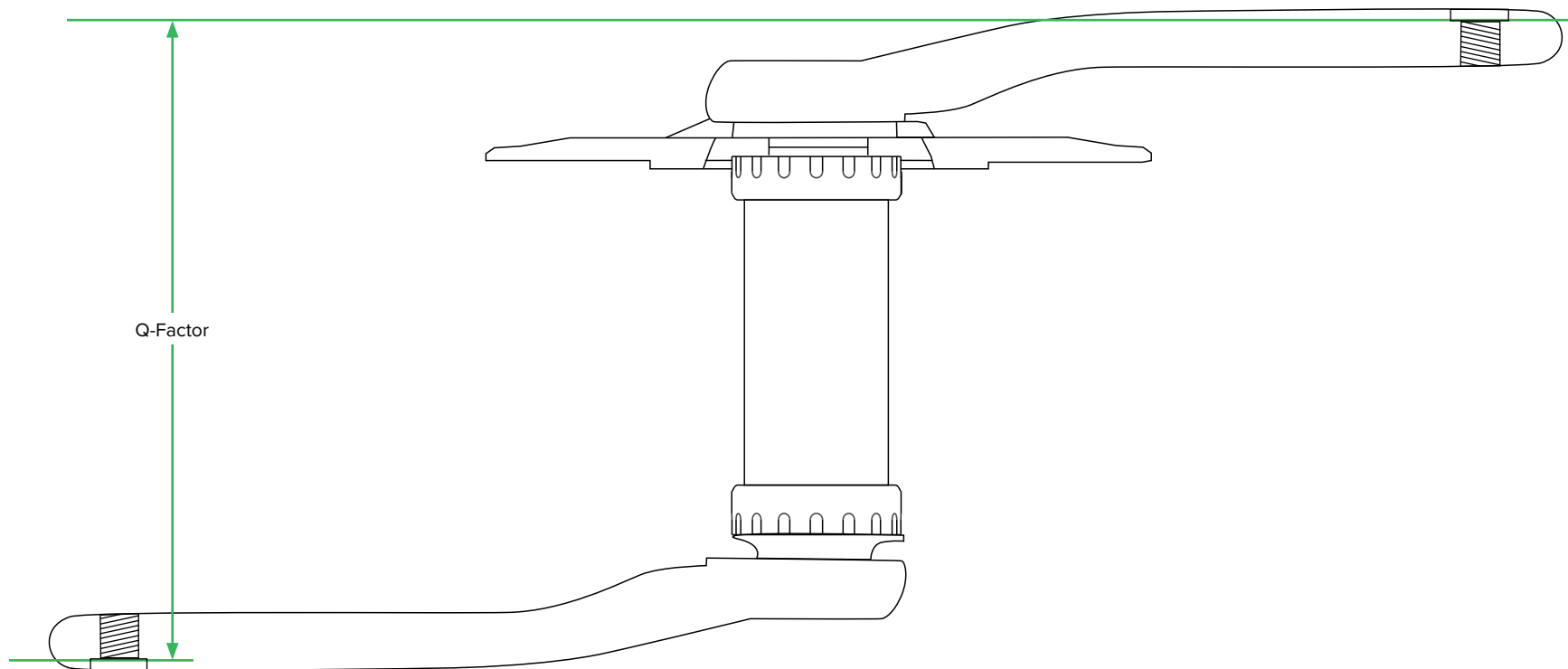

# Crank Boot

## Clearance Information

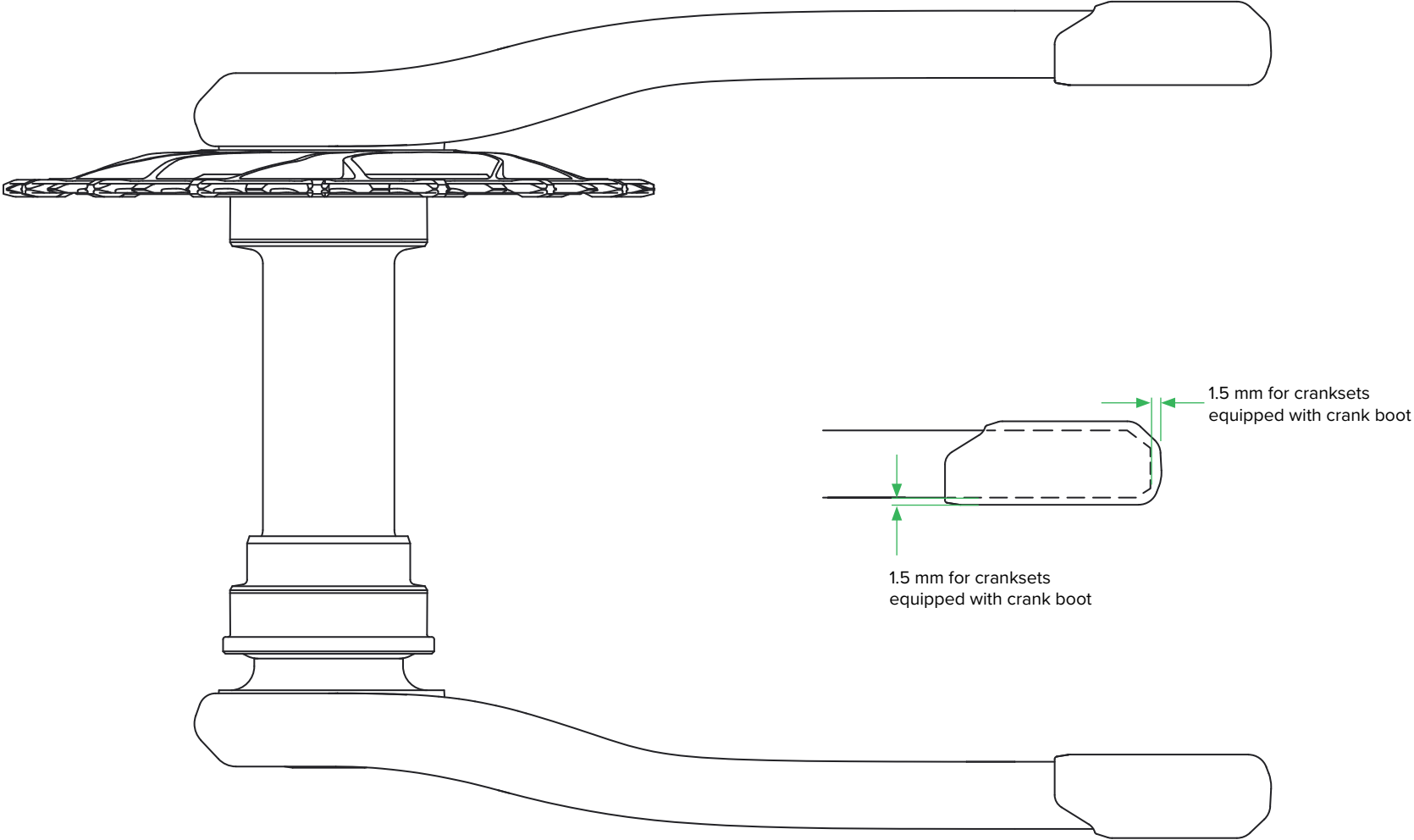

# 104 BCD Steel Chaining Spider Requirements

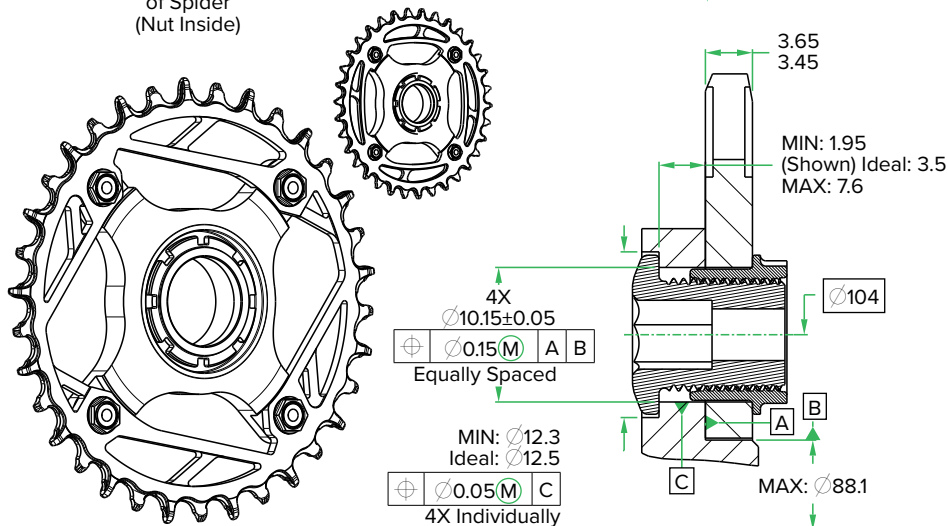
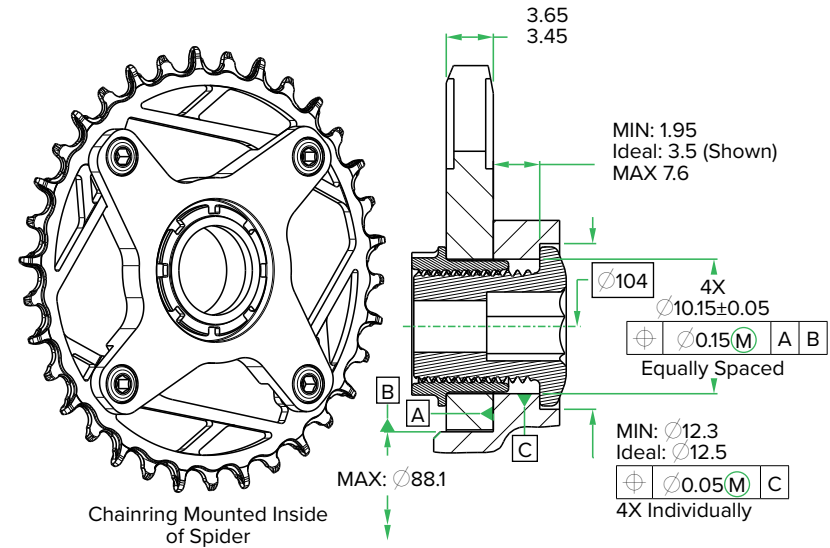
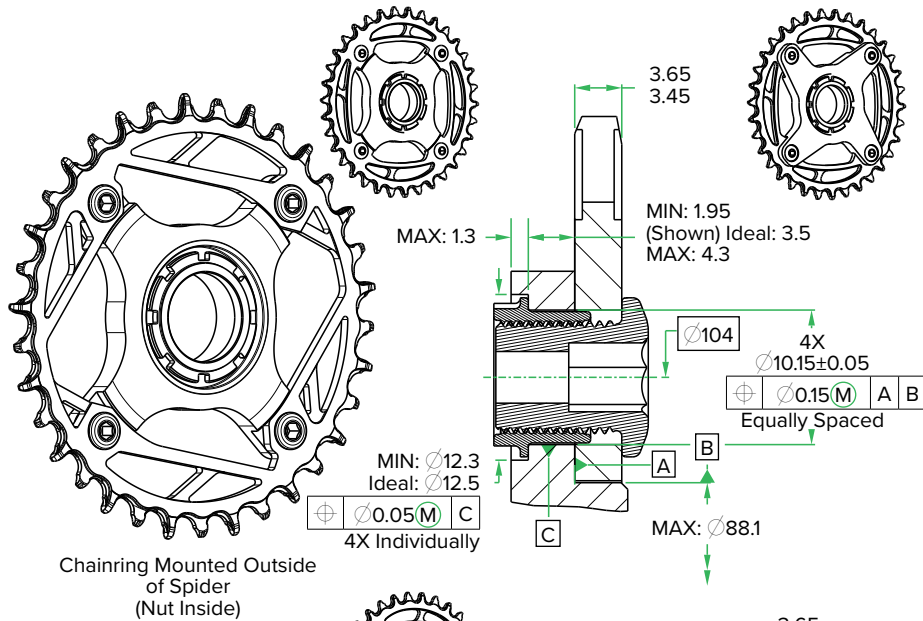

If the nut on the outside can be visually accepted the spider tab can be thicker than above.

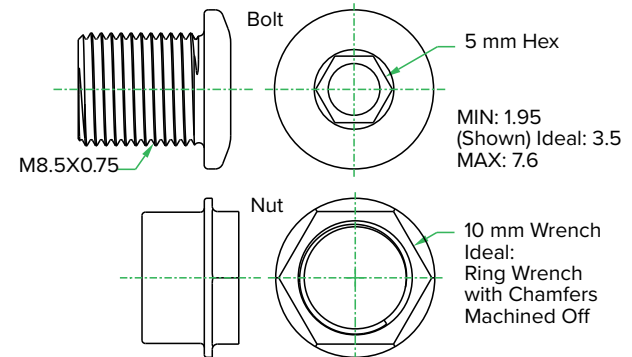

## Notes:

- 1 Always double-check spider geometry for interference with CAD chaining files provided in SRAM Connect downloads

# Bottom Bracket Shell Specifications

# BSA 68/73

## Bottom Bracket Shell Specifications

	W**	A*	B*
BSA 68	68	BC 1.37" x 24 TPI R.H.	BC 1.37" x 24 TPI L.H.
BSA 73	73		

\*Reference JIS B 0225

\*\*2.5 mm spacers may be used between the frame-shell and the adapter cups to adjust BB spacing.

BB shell contact face and threads must be free of paint.

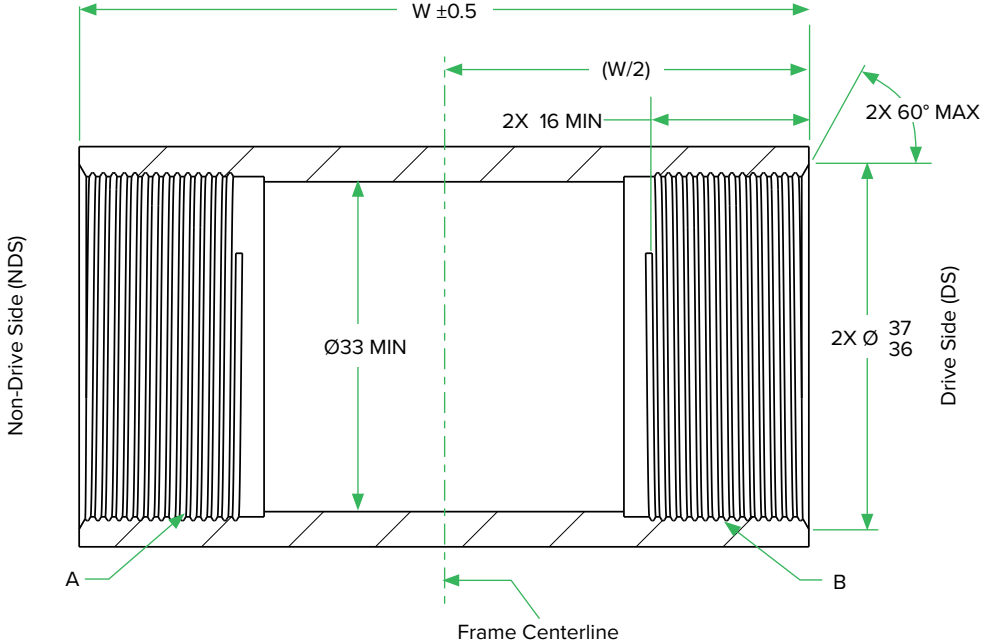
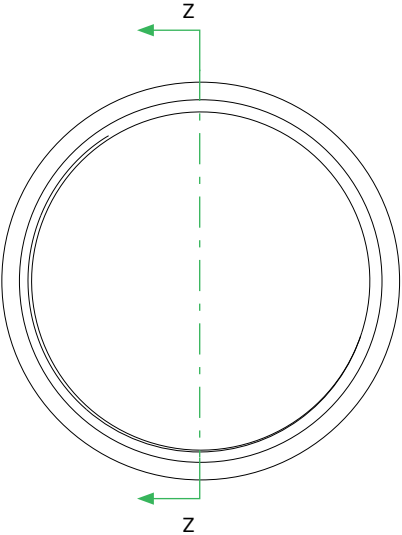

Section Z-Z

# PressFit 30 73

## MTB Bottom Bracket Frame Shell Specifications

SRAM PressFit 30 (PF30) bottom brackets have been designed and tested to work within the bounds of the dimensions and tolerances in the shell specifications. Materials, manufacturing methods, and frame shell designs can potentially influence the performance of the bottom bracket, even when the shell is manufactured to these specifications. In these instances, it is recommended that bicycle manufacturers confirm the bottom bracket system performance when implemented in their design.

Things that should be considered when evaluating the frame and bottom bracket interaction include, but are not limited to:

- Loosening of the adapter cups from the bottom bracket shell (frame material choice can greatly affect friction coefficient).
- Binding of bearings within the bottom bracket.

For more information regarding PF30 bottom bracket technical information, contact your SRAM representative.

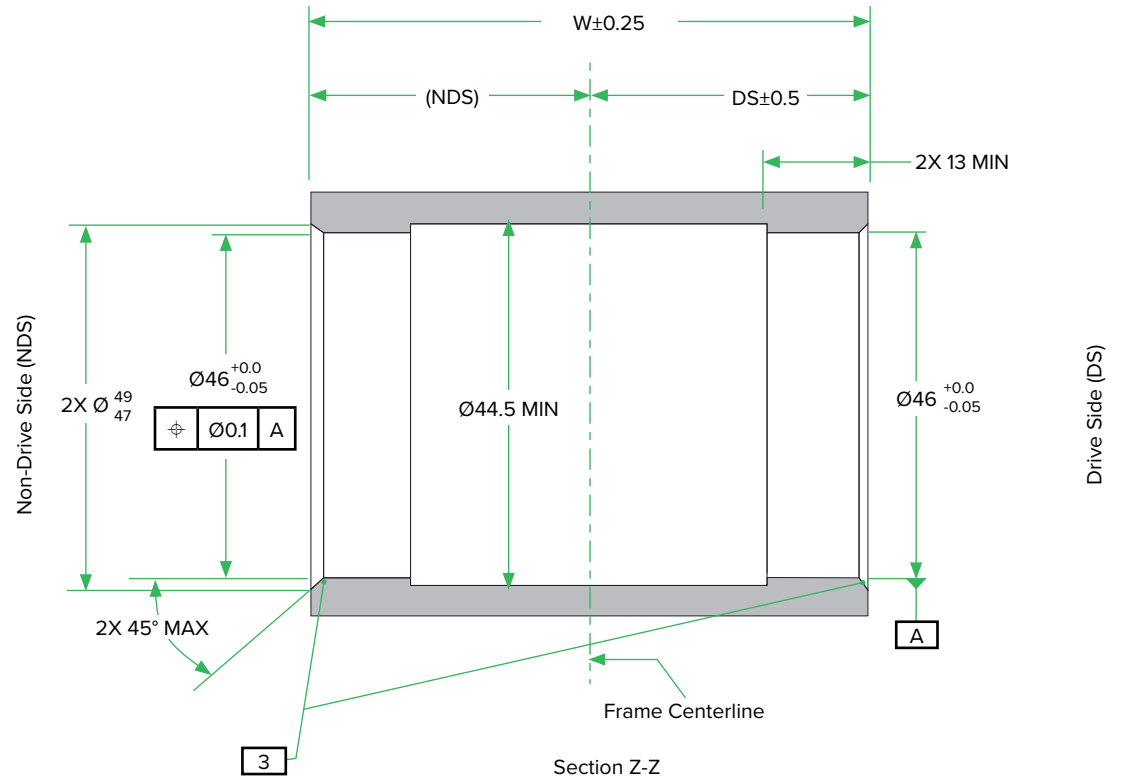
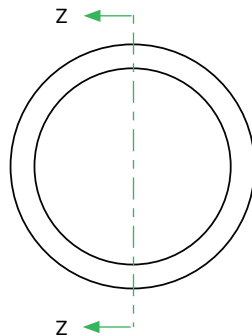

	Dim W	Dim DS	Dim NDS
PF30 73	73	36.5	36.5

- 1 Dimensions apply after finishing.
- 2 Only dimensions essential to bottom bracket PressFit and function are shown. All other details are left to the discretion of the frame or component designer. Dimensions shown do not take the place of proper frame, bottom bracket shell, or crankset design.
- 3 PressFit surfaces should be unpainted.

# PressFit

## Bottom Bracket Shell Specification

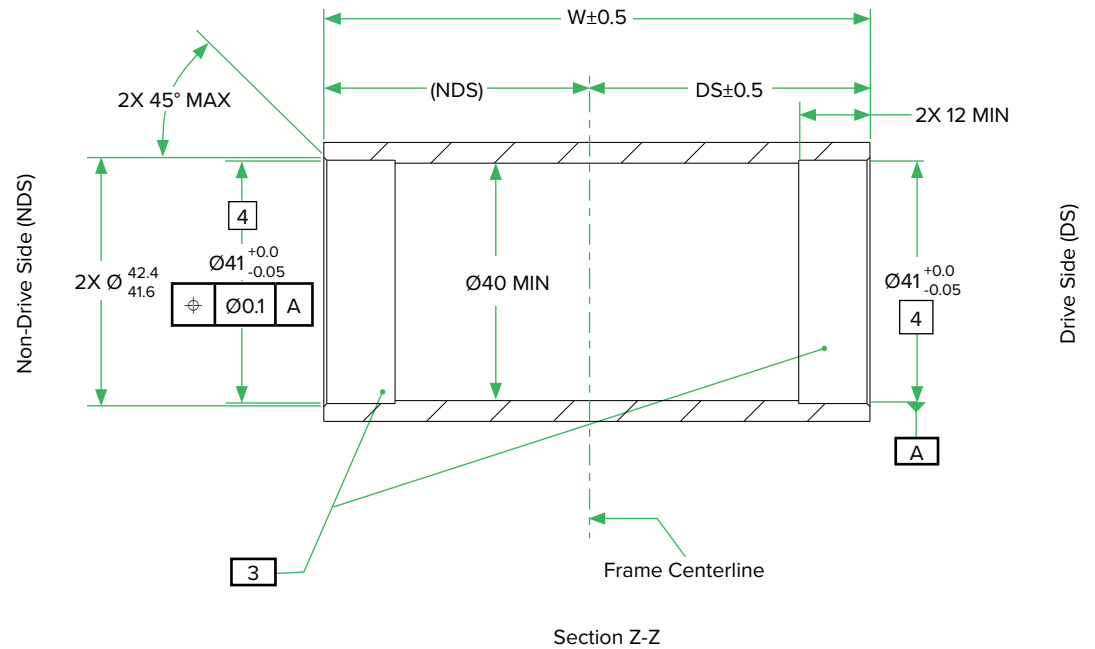
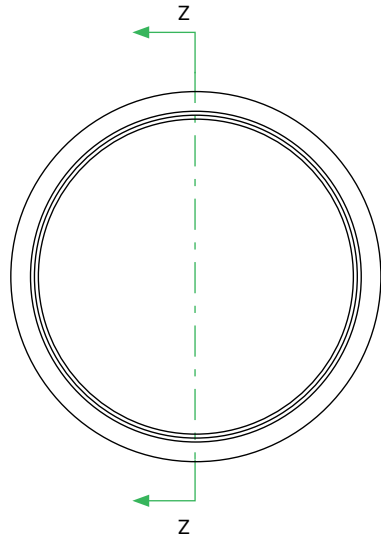

	Dim W	Dim NDS	Dim DS
PressFit 89.5	89.5	44.75	44.75
PressFit 92 ASYM	92	44.75	47.25

- 1 Dimensions apply after finishing.
- 2 Only dimensions essential to bottom bracket PressFit and function are shown. All other details are left to the discretion of the frame or component designer. Dimensions shown do not take the place of proper frame, bottom bracket shell, or crankset design.
- 3 PressFit surfaces should be unpainted.
- 4 Tolerance applies to depth of 12 mm inboard from the outer face of each side.

# BB30

## Bottom Bracket Shell Information

Information for the BB30 drawing and legal agreement can be found on [www.BB30standard.com](http://www.BB30standard.com). Use of the information contained in the drawing is forbidden without reviewing and agreeing to the legal terms and conditions found on [www.BB30standard.com](http://www.BB30standard.com). By using the information contained in the drawing you are certifying that you have agreed to the terms and conditions found within that legal agreement.

# DUB Bottom Brackets

# DUB BSA 68/73

## Bottom Bracket Specification

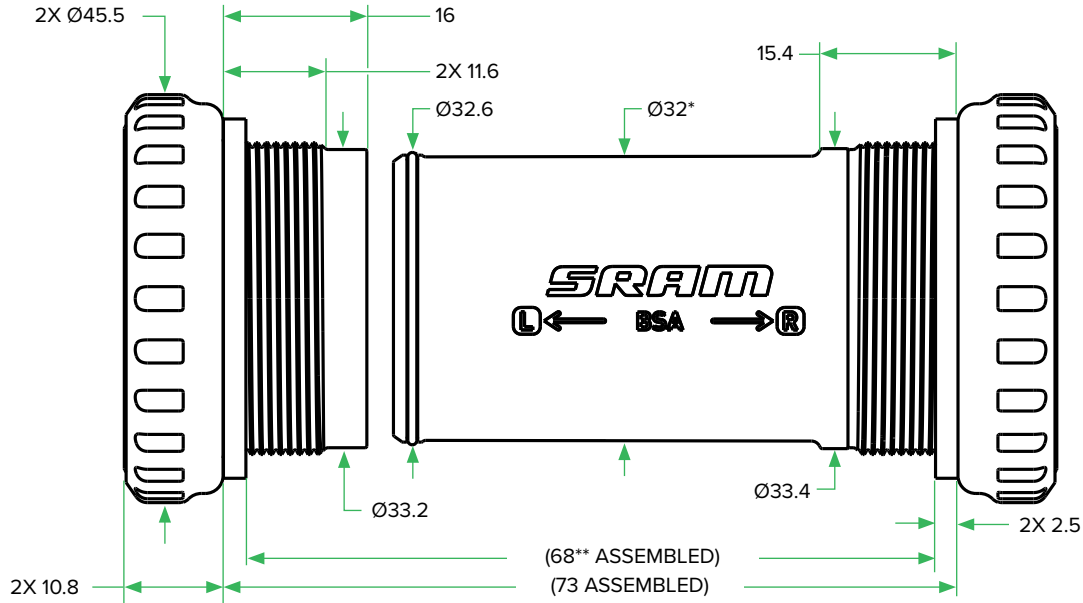

- 1 Dimensions apply after finishing.
- 2\* Only dimensions essential to bottom bracket fit and function are shown. All other details are left to the discretion of the frame or component designer. Dimensions shown do not take the place of proper frame, bottom bracket shell, or crankset design.  
**Consider cable and hose clearances through the bottom bracket area of the frame.**
- \*\* If a 68 mm configuration is used, 2 x 2.5 mm spacers must be installed.

# DUB PressFit MTB

## Bottom Bracket Specification

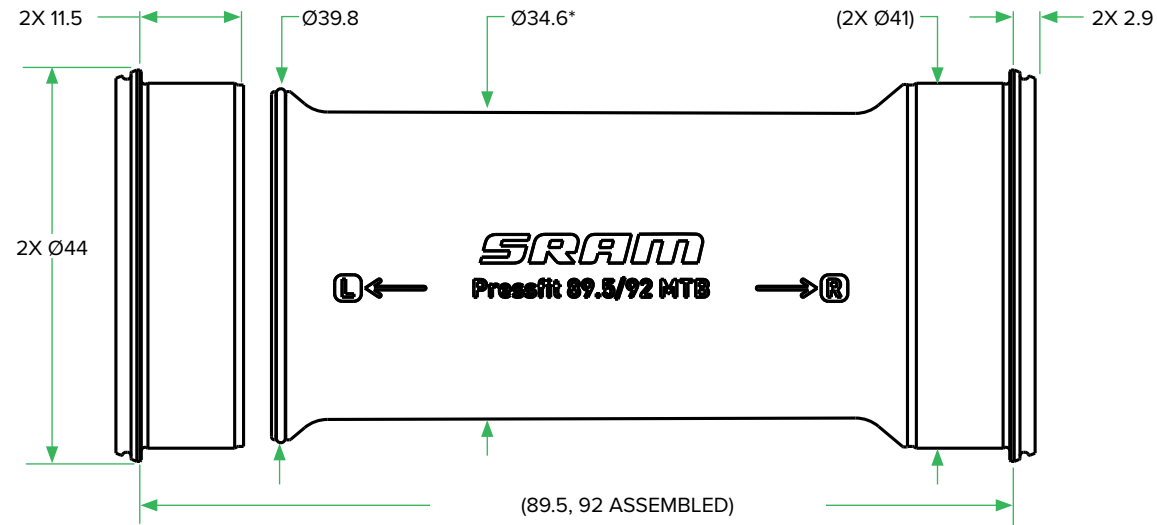

1 Dimensions apply after finishing.

2\* Only dimensions essential to bottom bracket fit and function are shown. All other details are left to the discretion of the frame or component designer. Dimensions shown do not take the place of proper frame, bottom bracket shell, or crankset design.

**Consider cable and hose clearances through the bottom bracket area of the frame.**

3 Ensure that the bottom bracket cups are completely pressed into the frame shell. There should be no gap between the flange and the bottom bracket shell.

# DUB PressFit 30

## Bottom Bracket Specification

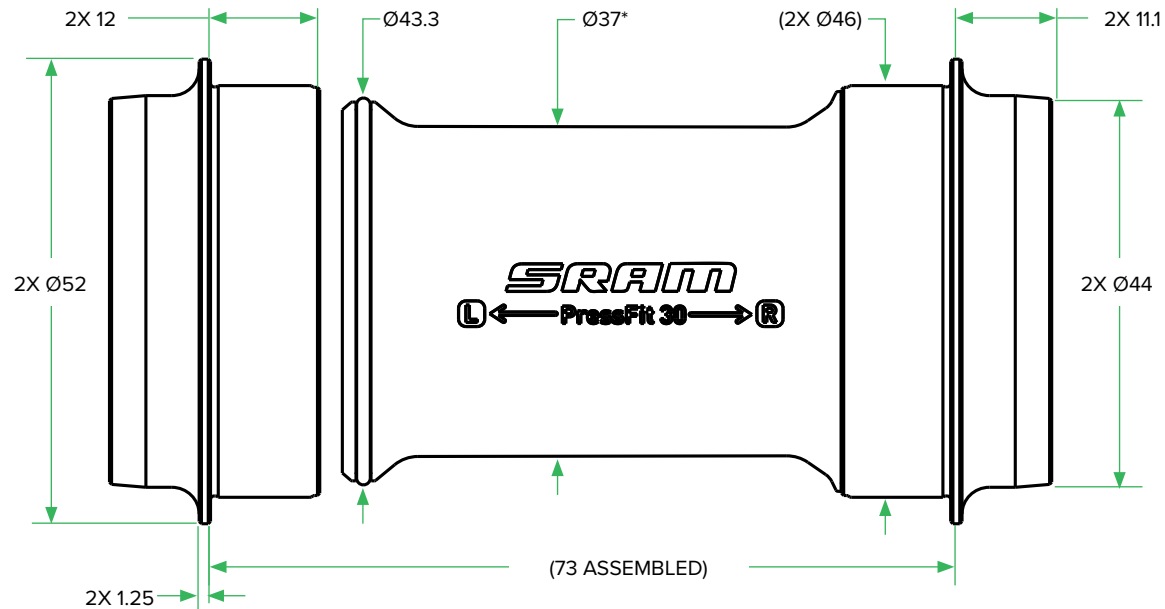

- 1 Dimensions apply after finishing.
- 2\* Only dimensions essential to bottom bracket fit and function are shown. All other details are left to the discretion of the frame or component designer. Dimensions shown do not take the place of proper frame, bottom bracket shell, or crankset design.  
**Consider cable and hose clearances through the bottom bracket area of the frame.**
- 3 Ensure that the bottom bracket cups are completely pressed into the frame shell. There should be no gap between the flange and the bottom bracket shell.

# DUB BB30

## Bottom Bracket Specification

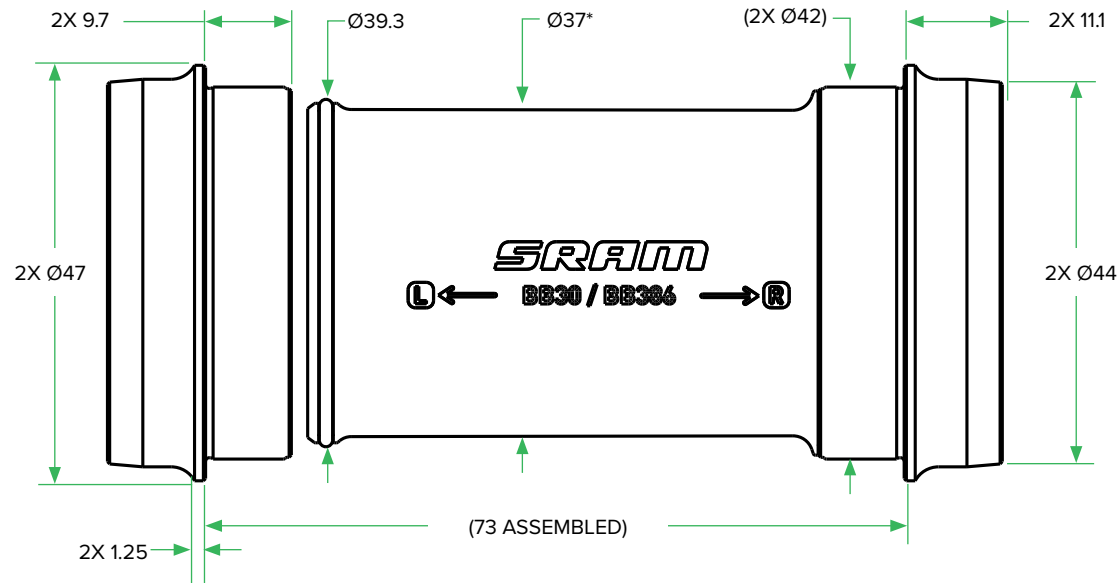

1 Dimensions apply after finishing.

2\* Only dimensions essential to bottom bracket fit and function are shown. All other details are left to the discretion of the frame or component designer. Dimensions shown do not take the place of proper frame, bottom bracket shell, or crankset design.

**Consider cable and hose clearances through the bottom bracket area of the frame.**

3 Ensure that the bottom bracket cups are completely pressed into the frame shell. There should be no gap between the flange and the bottom bracket shell.

---

ASIAN HEADQUARTERS

SRAM Taiwan  
No. 1598-8 Chung Shan Road  
Shen Kang Hsiang, Taichung City  
Taiwan

WORLD HEADQUARTERS

SRAM, LLC  
1000 W. Fulton Market, 4th Floor  
Chicago, Illinois 60607  
U.S.A.

EUROPEAN HEADQUARTERS

SRAM Europe  
Paasbosweg 14-16  
3862ZS Nijkerk  
The Netherlands